

NOTES:

REV		DESCRIPTION	DATE	APPROVED

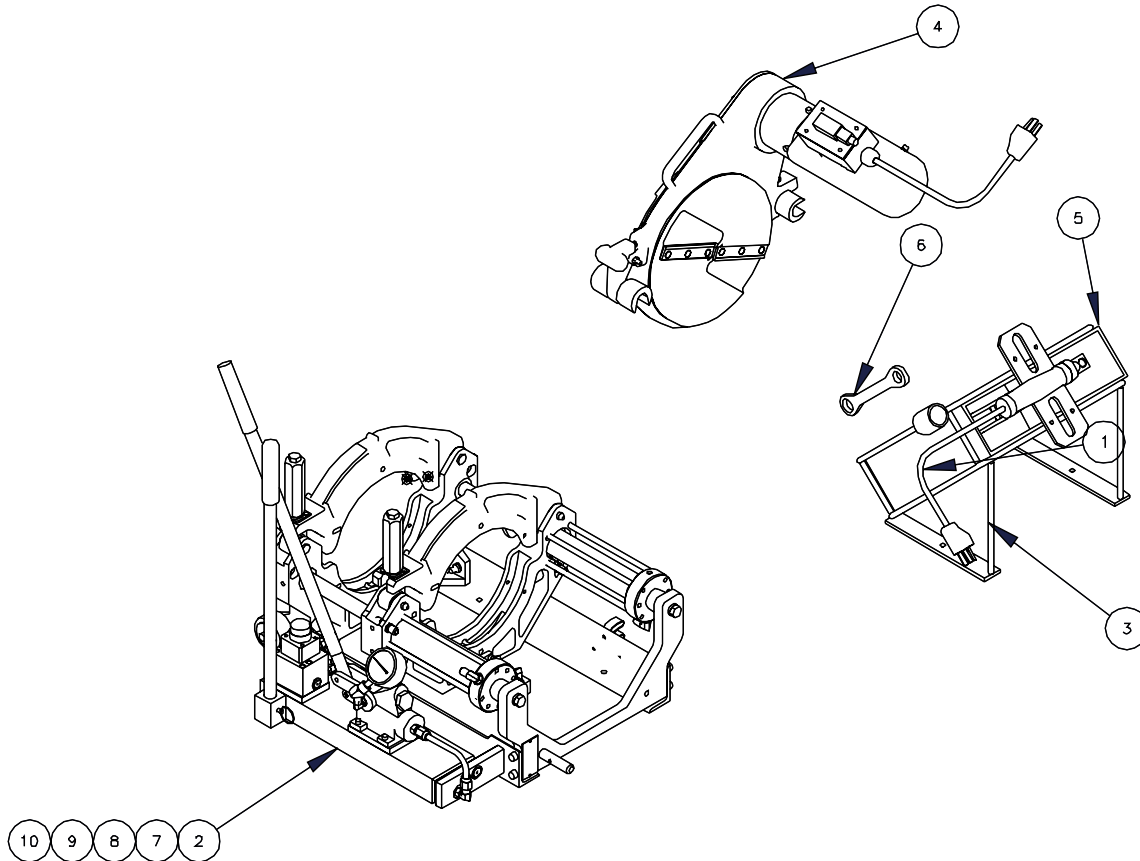

ITEM	QTY	PART NUMBER	DESCRIPTION
1	1	600266	HEATER ASSEMBLY, 28LM, 120VAC
2	1	200445	JIC ASSEMBLY, 28CQ(a)
3	1	600268	WELDMENT, HEATER FRAME, 28LM
4	1	500310	FACER ASSEMBLY, 28LM
5	1	28-8208-3520-10	BAG, HEATER
6	1	00-6684-0003-00	WRENCH, RATCHETING BOX
7	2	28-8208-6010-20	INSERT, UPPER, 8" DIPS X 8" IPS
8	2	28-8208-6020-20	INSERT, LOWER, 8" DIPS X 8" IPS
9	1	700100	NAMEPLATE, 28CQ(a) 120 VAC
10	2	00-2905-0300-03	SCREW, DR RD HD TYPE U #2 X 3/16

ALL DIMENSIONS ARE IN INCHES FRACTIONS: 1/16 DECIMALS: .125, .0625 / .015, .010 / .0015, .001 ANGULAR: 1° FINISH: 125		CONNECTRA FUSION TECHNOLOGIES, LLC	
DRAWN: D.L.WEST DATE: 03/25/03		DWD NO. 101125 SHEET 1 OF 1	

SIZE	MAIN ASSEMBLY USAGE							SUB-ASSEMBLY USED ON			
	10CQ	20CQ	10EP	20EP	10HP	20HP	40	QTY	ASSEMBLY	QTY	ASSEMBLY
4	-	-	-	-	-	-	-	-	-	-	-
8	-	-	-	-	-	-	-	-	-	-	-
14	-	-	-	-	-	-	-	-	-	-	-
18	-	-	-	-	-	-	-	-	-	-	-
24	-	-	-	-	-	-	-	-	-	-	-
36	-	-	-	-	-	-	-	-	-	-	-

APPR:	DATE:	DATE:	DATE:
CHECKED:	DATE:	DATE:	DATE:

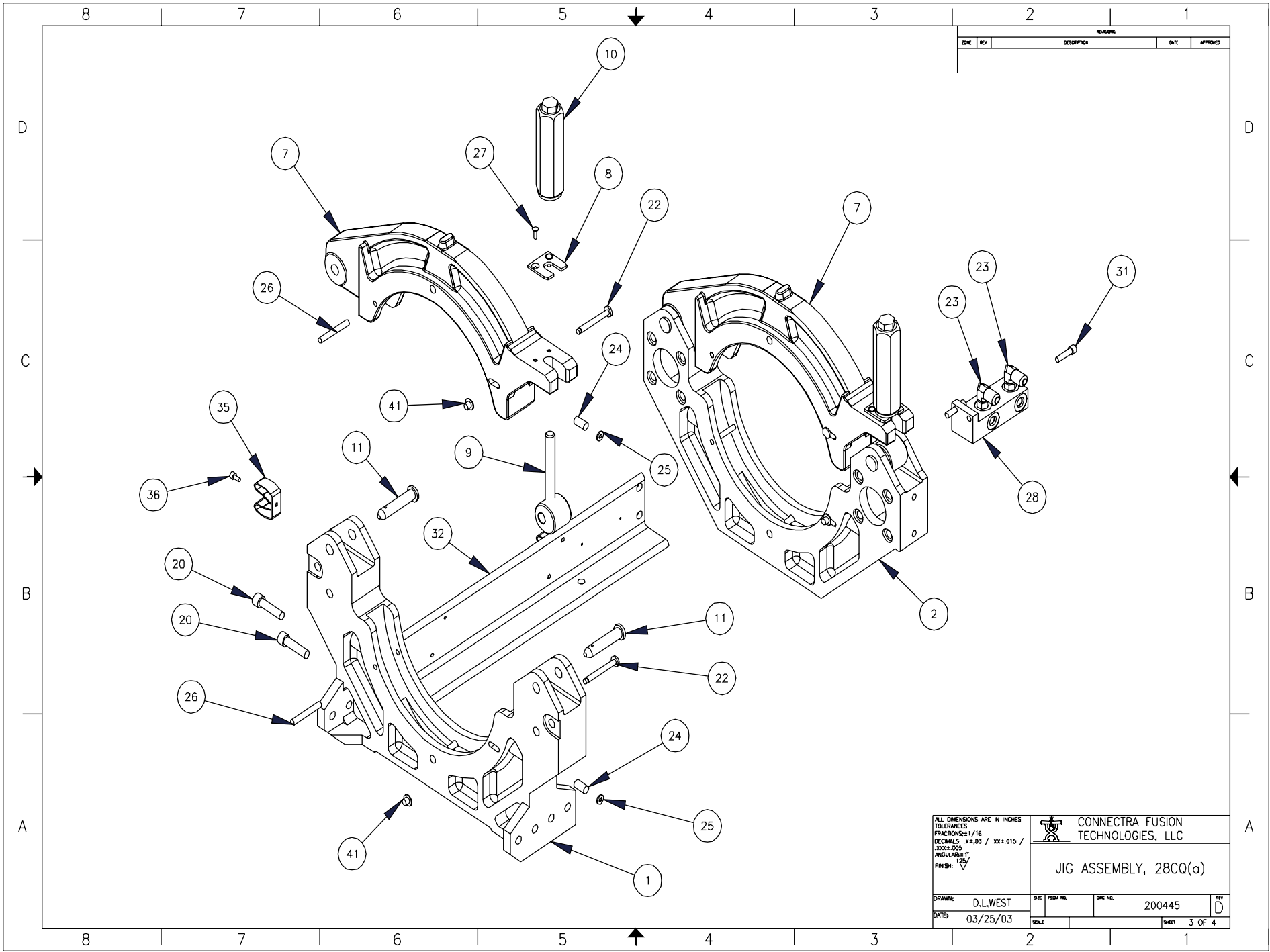

REVISIONS				
ZONE	REV	DESCRIPTION	DATE	APPROVED

ALL DIMENSIONS ARE IN INCHES TOLERANCES: FRACTIONS: 1/16 DECIMALS: .XX, .03 / .XX & .015 / .XXX & .005 ANGULAR: ± 1° FINISH:		 CONNECTRA FUSION TECHNOLOGIES, LLC		
JIG ASSEMBLY, 28CQ(α)				
DRAWN: D.L.WEST DATE: 03/25/03	SIZE: SCALE:	DWG. NO.: 200445	REV: D	SHEET: 3 OF 4

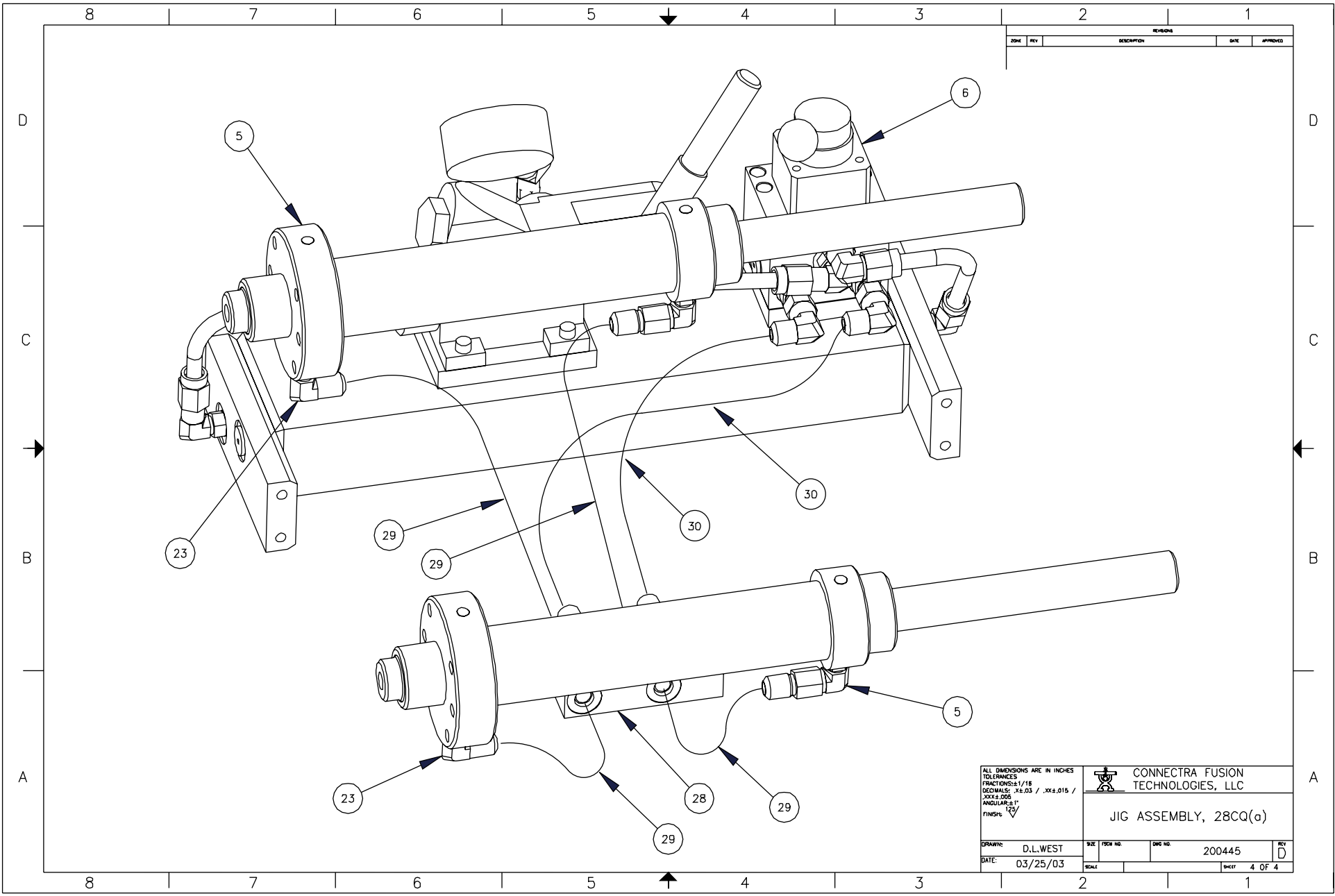

REVISIONS				
ZONE	REV	DESCRIPTION	DATE	APPROVED

ALL DIMENSIONS ARE IN INCHES
 TOLERANCES
 FRACTIONS: 1/16
 DECIMALS: .XX, .03 / .XX, .015 /
 .XXX & .005
 ANGULARS: 1°
 FINISH: 125

CONNECTRA FUSION TECHNOLOGIES, LLC
JIG ASSEMBLY, 28CQ(a)

DRAWN: D.L.WEST	SIZE: FICH NO.	DWG NO: 200445	REV: D
DATE: 03/25/03	SCALE:	SHEET: 4 OF 4	

8 7 6 5 4 3 2 1

NOTES:
 1. DISCARD RETAINING RING OF
 28-8602-9004-10, GROOVED CLEVIS.

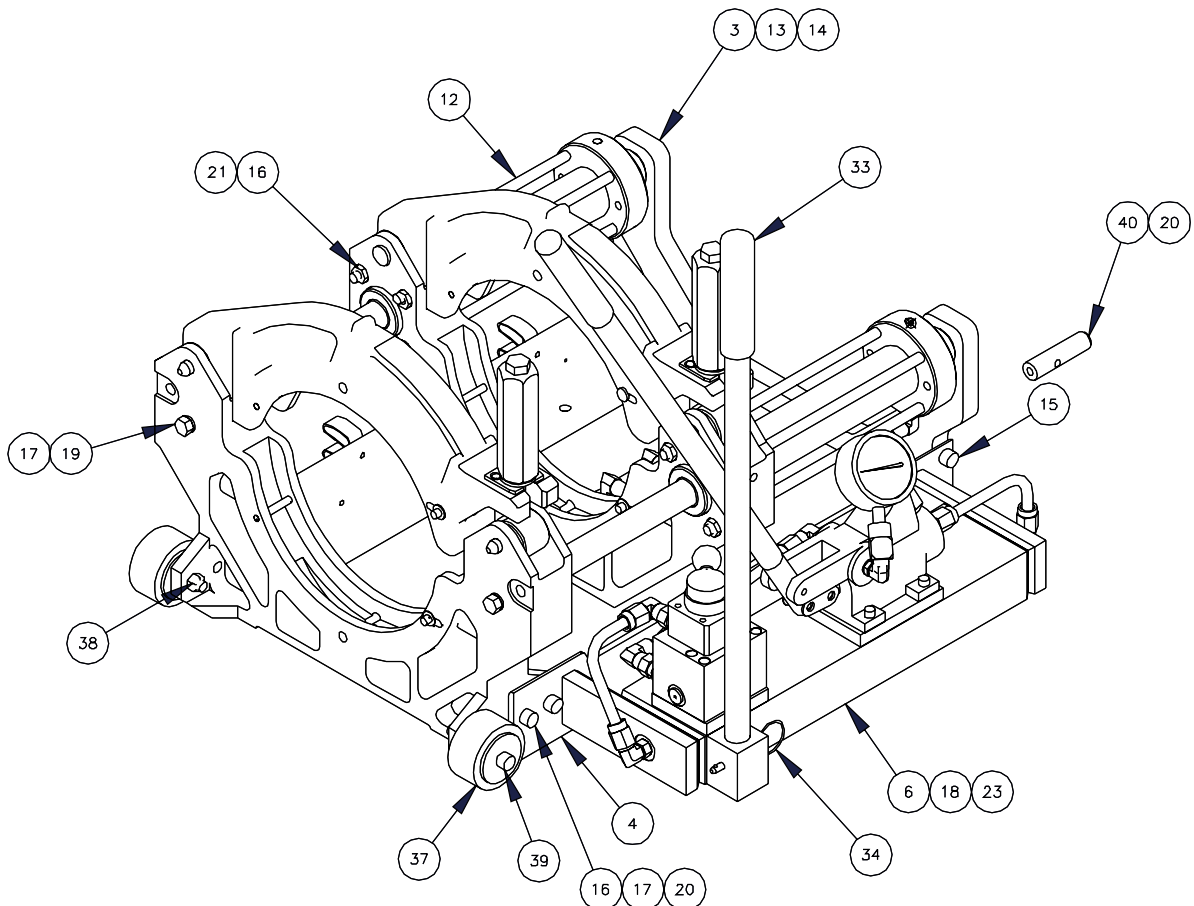

REV	DESCRIPTION	DATE	APPROVED
A	REMOVED FITTINGS HH0017, QTY 1, HH0018 AND HH0020	03/16/03	
B	CHANGED 28-8208-9210-20 TO 28-8602-9004-10, DELETED 00-7455-0001-00	12/12/03	
C	ADDED ONE 200447, TWO 00-6986-0004-00, TWO 00-0003-0003-00, TWO 00-0823-0600-20 AND ONE 00-0823-0600-12 SCREW	11/23/04	
D	ADDED 00-7455-0001-00	04/01/05	

ITEM	QTY	PART NUMBER	DESCRIPTION
1	1	200436	CLAMP, MODIFIED, LOWER STATIONARY
2	1	28-8208-9060-20	CLAMP, LOWER, SLIDING, LEFT
3	1	200438	PLATE, END
4	1	200439	ANGLE, LEFT SIDE
5	2	300390	CARRIAGE CYLINDER ASSEMBLY, 28CQ(a)
6	1	300372	RESERVOIR ASSEMBLY, 2B
7	2	28-8208-9050-20	CLAMP, UPPER, CF28
8	2	28-8204-4060-20	PLATE, WEAR
9	2	28-8208-4200-20	BOLT, TOGGLE, CF-28
10	2	28-8208-9150-30	HANDLE ASSEMBLY
11	4	00-6895-0003-00	PIN, COTTERLESS CLEVIS, .50 DIA X 2.00 GRIP
12	8	300371	ROD, CLAMP, CYLINDER
13	2	00-0203-0800-12	BOLT, HEX HD 500-13 UNC X 1.50" LG
14	2	00-0238-0005-00	WASHER, LOCK, 1/2
15	4	00-0823-0600-10	SCREW, SOCHD, 3/8-16 X 1.25
16	12	00-0036-0003-00	NUT, FIN HEX 3/8-16NC-2 PLTD
17	12	00-0238-0003-00	WASHER, LOCK, 3/8
18	4	00-0823-0500-10	SCREW, SOCHD, 5/16-18 X 1.25
19	2	00-0203-0600-22	BOLT, HEX HD 3/8-16 UNC X 2.75" LG
20	5	00-0823-0600-12	SCREW, SOCHD, 3/8-16 X 1.50
21	8	00-6985-0001-00	WASHER, FLAT, 3/8, THIN
22	4	28-8602-9004-10	GROOVED CLEVIS W/ RET RING LG 2.25", DIA 1/4", 18-8 SS
23	4	HH0017	90 4 BOSS / 6 37 FLARE
24	4	28-8204-4330-10	SPRING, CPRSM .035" WIRE DIA
25	4	00-6977-0001-00	RING, RETAINING INTERNAL
26	4	00-0215-0130-00	PIN, SPRING, .250 DIA X 2.00
27	4	00-6994-0002-04	SCREW, SELF-TAPPING TYPE F #8-.32 X .50" LONG BLUNT POINT
28	1	300381	MANIFOLD, QUICK CONNECT
29	4	310016	HOSE ASSEMBLY, MANIFOLD/CYLINDER, 28LM
30	2	310017	HOSE ASSEMBLY, SUBPLATE/MANIFOLD, 28LM
31	2	00-0823-0400-08	SCREW, SOCHD, 1/4-20 X 1.00
32	1	200440	ANGLE, RIGHT SIDE
33	1	200441	HANDLE ASSEMBLY, 28LM
34	1	V00223	PIN, QUICK RELEASE, STAINLESS, .25 DIA X 2.00 GRIP
35	4	V00946	TOOL, HOLDER
36	4	00-0823-0300-03	SCREW, SOCHD, 10-24 X .38
37	1	00-6986-0004-00	WHEEL, RUBBER, .375 AXLE
38	2	00-0003-0003-00	NUT, 3/8-16 UNC, ESNIA
39	2	00-0823-0600-20	SCREW, SOCHD, 3/8-16 X 2.50
40	1	200447	STUD, HANDLE, 28CQ(a)/LM
41	4	00-7455-0001-00	NUT, PUSH, .25 DIA

SIZE	MAIN ASSEMBLY USAGE							SUB-ASSEMBLY USED ON			
	10CQ	20CQ	10EP	20EP	10HP	20HP	28CQA	QTY	ASSEMBLY	QTY	ASSEMBLY
4								1	(1) 100125		
8							1 (1)				
14											
18											
24											
36											

ALL DIMENSIONS ARE IN INCHES
 TOLERANCES
 FRACTIONS: ±1/16
 DECIMALS: .XX, .03 / .XX, .015 /
 ANGULARS: ±1°
 FINISH:

CONNECTRA FUSION TECHNOLOGIES, LLC

JIG ASSEMBLY, 28CQ(a)

APPR: D.L.WEST DATE: 03/25/03
 CHECKED: DATE: DATE: 03/25/03

DRAWN: D.L.WEST
 REV: 1 OF 4
 SHEET: 1 OF 4

8 7 6 5 4 3 2 1

8 7 6 5 4 3 2 1

NOTES:

REV		DESCRIPTION	DATE	APPROVED

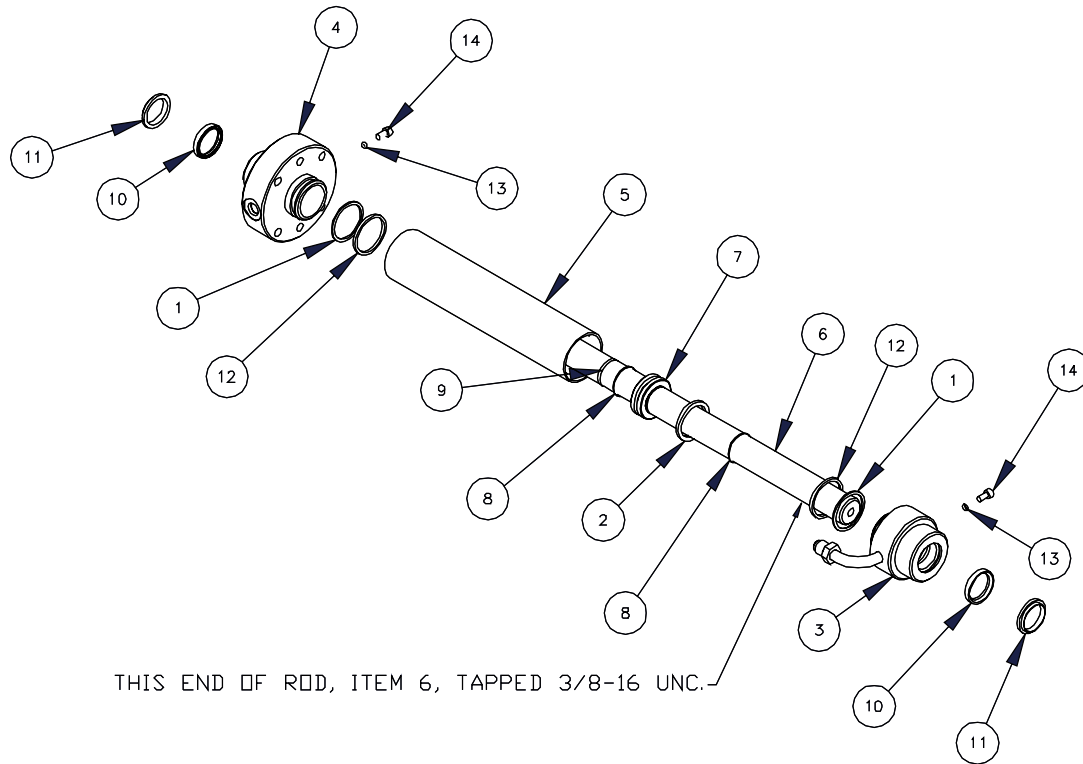

THIS END OF ROD, ITEM 6, TAPPED 3/8-16 UNC.

ITEM	QTY	PART NUMBER	DESCRIPTION
1	2	V00141	BACKUP RING, 573-125 HERC.
2	1	V00153	SEAL, PISTON, PTFE, 1.50 BORE X .116
3	1	300366	FRONT ENDCAP ASSEMBLY
4	1	300358	ENDCAP, REAR
5	1	300391	CYLINDER, HYDRAULIC
6	1	300370	ROD, PISTON
7	1	300104	PISTON, CARRIAGE CYLINDER
8	2	V00120	RING, SPIRAL RETAINING, 1.00" LD.
9	1	V00139	SEAL, O RING, 568-117 HERC.
10	2	V00179	U-SEAL, ROD, 1.00 X 1 1/4 X 3/16 HERC.
11	2	V00188	WIPER RING, 1.00 X 1.272 X .104
12	2	V00140	SEAL, O RING, 568-125 HERC.
13	2	V00128	SEAL, O RING, #006
14	2	HS0025	SCREW, SOCHD, 10-32 X .38

ALL DIMENSIONS ARE IN INCHES
 TOLERANCES:
 FRACTIONS: 1/16
 DECIMALS: .005 / .015 /
 UNLESS NOTED
 FINISH: 125

CONNECTRA FUSION TECHNOLOGIES, LLC
CARRIAGE CYLINDER ASSEMBLY, 28CQ(a)

APPR: D.L.WEST	DATE:	DATE: 03/25/03	REV:
CHECKED:	DATE:	DATE:	REV:

SIZE	MAIN ASSEMBLY USAGE							SUB-ASSEMBLY USED ON			
	10CQ	20CQ	10EP	20EP	10HP	20HP	28CQA	QTY	ASSEMBLY	QTY	ASSEMBLY
4	-	-	-	-	-	-	-	2	(1) 200445	-	-
8	-	-	-	-	-	-	2 (1)	-	-	-	-
14	-	-	-	-	-	-	-	-	-	-	-
18	-	-	-	-	-	-	-	-	-	-	-
24	-	-	-	-	-	-	-	-	-	-	-
36	-	-	-	-	-	-	-	-	-	-	-

8 7 6 5 4 3 2 1

8

7

6

5

4

3

2

1

NOTES:

REV	REV	DESCRIPTION	DATE	APPROVED
A		ADDED FITTINGS QTY 2, HH0018 AND HH0020		

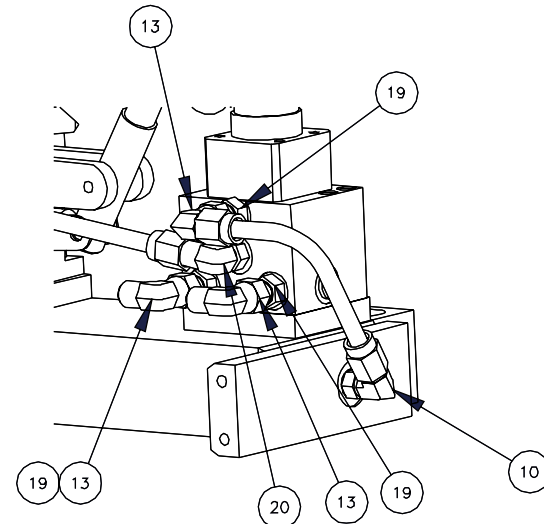
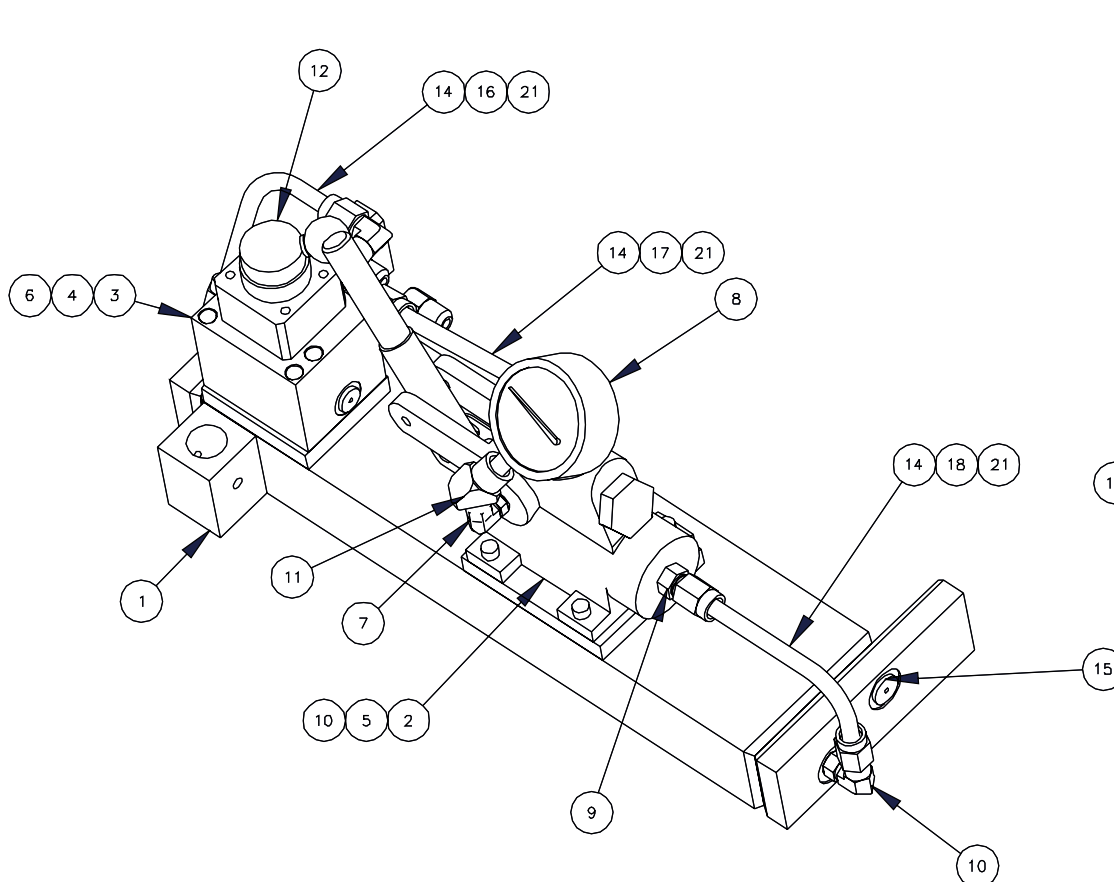

ITEM	QTY	PART NUMBER	DESCRIPTION
1	1	300373	WELDMENT, RESERVOIR, 2B
2	1	300379	MODIFIED PUMP ASSEMBLY, 2B
3	1	300311	HYDRAULIC SUBPLATE
4	2	V00493	HOLLOW HEX PLUG, NO. 4
5	4	HS0019	SCREW, SOCHD, 1/4-20 X .75
6	4	HS0022	SCREW, SOCHD, 1/4-20 X 2.50
7	1	00-0699-0323-00	ELBOW, 90 DEG EXTRA LONG, PARKER #6-1/4 AEOG
8	1	V00191	GAUGE, PRESSURE, 0-2000 PSI
9	1	HH0023	STRAIGHT 6 BOSS / 6 37 FLARE
10	3	HH0019	90 6 BOSS / 6 37 FLARE
11	1	V00710	FITTING, HYD, 4MP-4FP 45 STREET ELBOW
12	1	300388	DIRECTIONAL VALVE, MODIFIED
13	3	HH0018	90 6 37 FLARE SWIVEL
14	6	HH0022	6 FLARELESS TUBE FERRULE
15	1	V00494	HOLLOW HEX PLUG, NO. 6
16	1	300384	TUBE, RETURN
17	1	300385	TUBE, PUMP/VALVE
18	1	300386	TUBE, SUMP
19	3	HH0020	STRAIGHT 4 BOSS / 6 37 FLARE
20	1	HH0017	90 4 BOSS / 6 37 FLARE
21	6	HH0021	6 FLARELESS TUBE NUT

ALL DIMENSIONS ARE IN INCHES
 TOLERANCES:
 FRACTIONS: 1/16
 DECIMALS: .04, .03 / .XX, .010 /
 .XXX, .005
 ANGLES: 90° ± 1°
 FINISH: 12.5

CONNECTRA FUSION TECHNOLOGIES, LLC

RESERVOIR ASSEMBLY, 28LM

APP'R:	DATE:	DRAWN: D.L.WEST	SHEET FROM NO.:	DSG NO.:	300372	REV: A
CHECKED:	DATE:	DATE: 02/13/03	SCALE:	SHEET 1 OF 1		

SIZE	MAIN ASSEMBLY USAGE							SUB-ASSEMBLY USED ON			
	10CQ	20CQ	10EP	20EP	10HP	20HP	28	QTY	ASSEMBLY	QTY	ASSEMBLY
4	-	-	-	-	-	-	-	1	(1) 200435	-	-
8	-	-	-	-	-	-	1 (1)	-	-	-	-
14	-	-	-	-	-	-	-	-	-	-	-
18	-	-	-	-	-	-	-	-	-	-	-
24	-	-	-	-	-	-	-	-	-	-	-
36	-	-	-	-	-	-	-	-	-	-	-

8

7

6

5

4

3

2

1

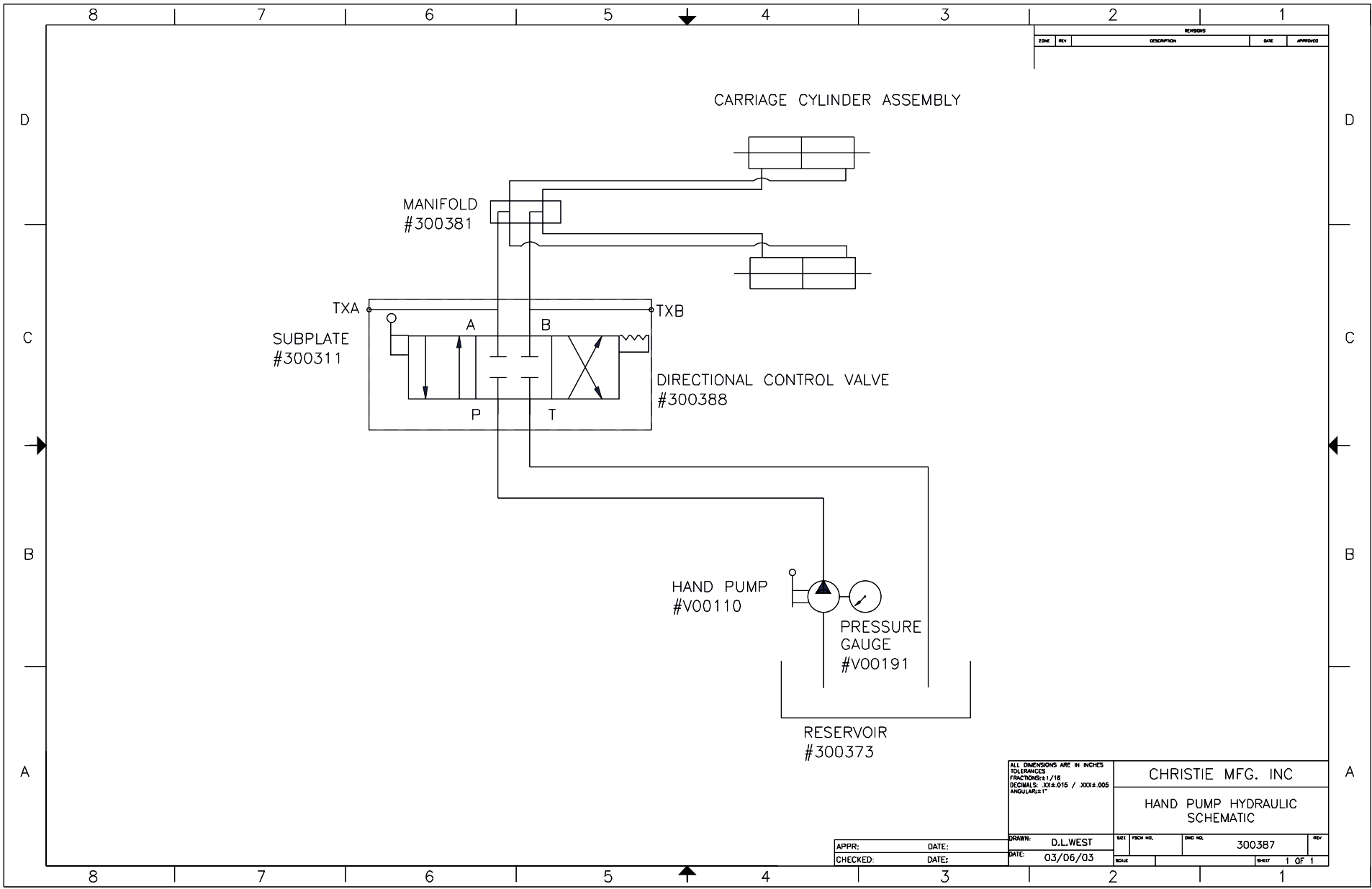

NOTES:
1. APPLY LOCKTITE 243 TO SCREWS, ITEMS 16 AND 18.

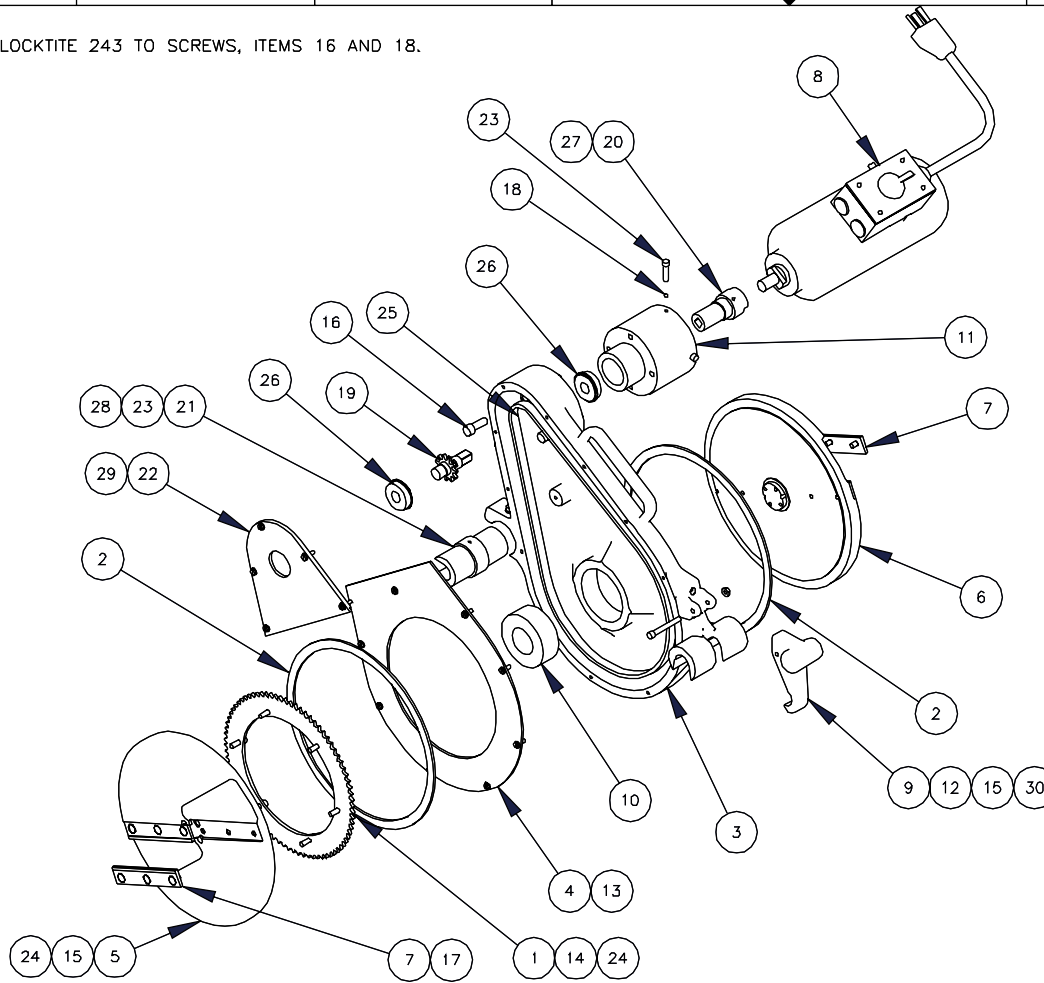

REV	DATE	DESCRIPTION	BY	APPROVED
A	06/14/04	ITEM 18 WAS V00819, NOW HS0018, ADDED V00965		
B	06/24/04	DELETED HS0018, ADDED QTY 2 HS0020		

ITEM	QTY	PART NUMBER	DESCRIPTION
1	1	28-8208-4610-20	SPROCKET, DRIVEN
2	2	28-8208-4640-20	WASHER, FELT
3	1	500311	FACER BODY, 28LM
4	1	500313	COVER, FACER, 28LM FACER
5	1	28-8208-4540-20	FRONT FACER PLATE
6	1	28-8208-4550-20	REAR FACER PLATE
7	4	28-8208-4560-20	BLADE, CENTREFUSE 28
8	1	400016	FACER MOTOR ASSEMBLY 120VAC
9	1	28-8204-4530-20	HANDLE, LOCKING
10	1	28-8539-0900-10	BEARING, RADIAL BALL
11	1	500314	NOSE CONE, FACER, 28
12	1	00-0003-0001-00	NUT, 1/4-20 UNC, ESNA
13	8	00-6688-1024-04	SCREW, SELF TAPPING, 10-24 X .50
14	6	00-0130-0400-06	SCREW, SOCHD, 1/4-20 X .75
15	5	00-0130-0400-16	SCREW, SOCHD, 1/4-20 X 2.00
16	4	00-0130-0600-08	SCREW, SOCHD, 3/8-16 X 1.00
17	12	00-6983-0400-04	SCREW, FLTHD, 1/4-20 X .50
18	2	V00965	BALL, THERMOPLASTIC, NYLON, 3/16" DIA
19	1	500124	DRIVE SPROCKET ASSEMBLY, 11 TOOTH
20	1	500129	WELDMENT, FACER MOTOR ADAPTER
21	1	500315	STOP, FACER, 28LM
22	1	500312	COVER, BEARING MOUNT, 28LM FACER
23	3	HS0020	SCREW, SOCHD, 1/4-20 X 1.00
24	10	00-0238-0001-00	WASHER, LOCK, 1/4
25	1	500316	CHAIN, SPROCKET
26	2	V00003	BEARING, W/SNAPRING, 203S22ZC
27	1	HS0012	SCREW, SET, 1/4-20 X .50
28	1	HW0006	WASHER, LOCK, 1/4
29	5	HS0108	SCREW, SELF TAPPING, 10-24 X .63
30	1	00-0136-0177-00	SPRING, COMPRESSION

ALL DIMENSIONS ARE IN INCHES
TOLERANCES
FRACTIONS: 1/16
DECIMALS: .XX, .XX / .XXX, .015 / .XXX
XXXL, .005
UNLESS NOTED
FINISH: 125

CONNECTRA FUSION TECHNOLOGIES, LLC

FACER ASSEMBLY, 28LM

DRAWN: D.L.WEST
DATE: 02/03/03

REV B

1 OF 1

SIZE	MAIN ASSEMBLY USAGE							SUB-ASSEMBLY USED ON			
	10CQ	20CQ	10EP	20EP	10HP	20HP	28	QTY	ASSEMBLY	QTY	ASSEMBLY
4	1	(1) 101110	.	.
8	1 (1)
14
18
24
36

APPR: DATE:
CHECKED: DATE:

REVISIONS				
ZONE	REV	DESCRIPTION	DATE	APPROVED

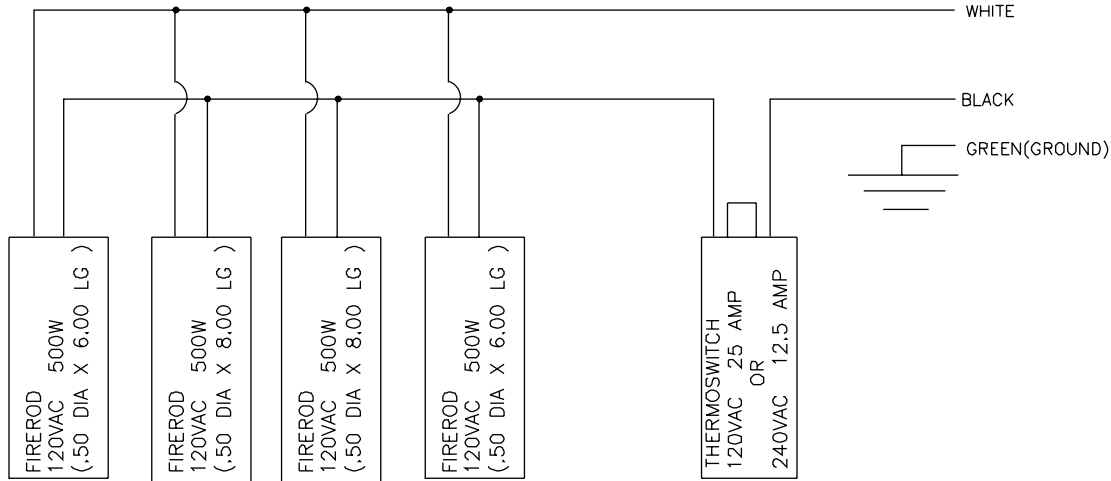

QUANTITY	FIRE ROD	TOTAL WATTS	TOTAL AMPS
4	120V 500W	2000	16.6

ALL DIMENSIONS ARE IN INCHES
 TOLERANCES
 FRACTIONS: ±1/16
 DECIMALS: .XX±.015/.XXX±.005
 ANGULAR: ±1°

CHRISTIE MANUFACTURING INC.
 WIRING DIAGRAM, 8" HEATER
 120VAC

DRAWN: D.L.WEST	SIZE	FSDM NO.	DWG NO. 400007	REV
DATE: 04/18/99	SCALE	SHEET		