

NOTES:

REV	DESCRIPTION	DATE	APPROVAL
D	CHANGED 28-8204-7000-30 TO 28-8204-7005-30	01/28/06	
E	CHANGED 28-8204-7005-30 TO 28-8204-7010-30	09/19/07	
F	ADDED 28-8204-3550-10 HEATER BAG	10/03/07	
G	REPLACED 28-8204-7200-30 WITH 28-8204-7240-30	03/19/08	

ITEM QTY	PART NUMBER	DESCRIPTION
1	28-8204-1000-30	JOINING ASSEMBLY, 14M
1	28-8204-1500-30	HEATER ASSEMBLY, 14M
1	28-8204-2240-30	HEATER ASSEMBLY, 120 VAC
1	28-8204-7981-30	14M HEATER ASSEMBLY, 120 VAC
1	00-1688-0042-04	14M OPERATING INSTR VIDEO/TARE
1	00-3785-0286-00	INSTRUCTION MANUAL F/CF-14B
1	28-8204-3500-10	BAG, HEATER, 14M

SIZE	MAIN ASSEMBLY USAGE						SUB-ASSEMBLY USED ON					
	10C0	20C0	10EP	20EP	10HP	20HP	40	QTY	ASSEMBLY	QTY	ASSEMBLY	
4							40					
8												
14												
18												
24												
36												

APPR: D.L. WEST
 DATE: 09/25/03
 CHECKED: _____
 DATE: _____

CONNECTRA FUSION
 TECHNOLOGIES, LLC
 14M SYSTEM
 ASSEMBLY 120 VAC

REV: 28-0204-3020-40 C
 SHEET 1 OF 2

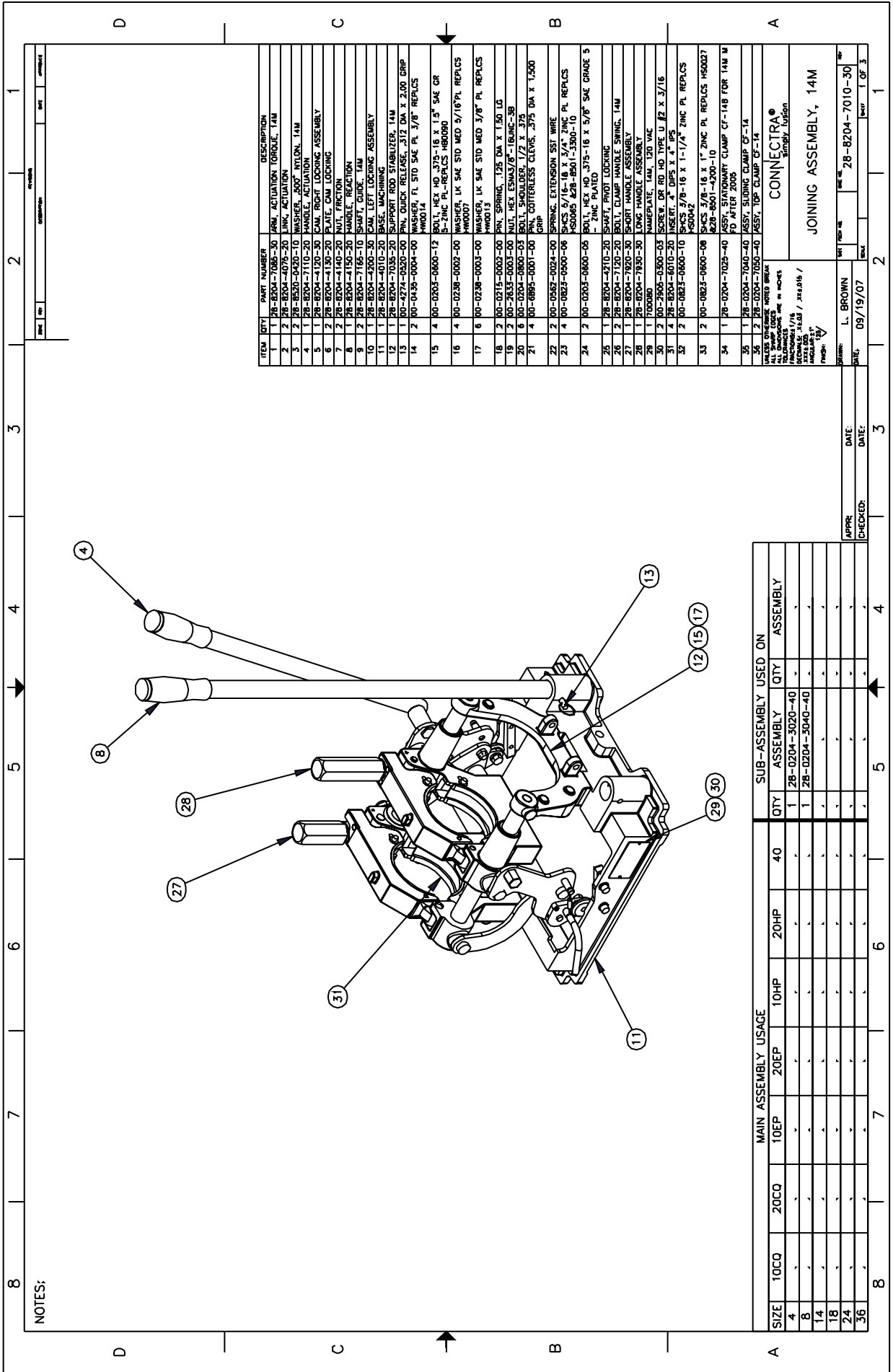

NOTES:

ITEM	QTY	PART NUMBER	DESCRIPTION
1	1	28-8204-7085-30	ARM, ACTUATION TORQUE, 14M
2	2	28-8204-4075-20	LINK, ACTUATION
3	2	28-8204-0420-10	WASHER, 3000 NYLON, 14M
4	1	28-8204-7110-20	HANDLE, ACTUATION
5	1	28-8204-1120-30	CAM, RIGHT LOCKING ASSEMBLY
6	2	28-8204-1130-30	PLATE, CAM LOCKING
7	2	28-8204-1140-30	NUT, FRICTION
8	1	28-8204-1150-20	HANDLE, REACTION
9	2	28-8204-7165-10	SHAFT, GUIDE, 14M
10	1	28-8204-7170-30	CAM, LEFT LOCKING ASSEMBLY
11	1	28-8204-7180-30	SPRING, EXTENSION SST WIRE
12	1	28-8204-7195-30	SUPPORT ROD STABILIZER, 14M
13	1	28-8204-7205-30	SHOULDER, 1/2 X 3/8
14	1	28-8204-7215-30	BOLT, SHOULDER, 1/2 X 3/8
15	1	00-4374-0020-00	PNL QUICK RELEASE, 3/12 DIA X 2.00 GRIP
16	2	00-0436-0004-00	WASHER, FL 570 SAE PL 3/8" REPLCS H#0014
17	4	00-0203-0600-12	BOLT, HEX HD .375-16 X 1.5" SAE GR
18	4	00-0236-0002-00	WASHER, LK SAE STD MED 5/16" PL REPLCS B-ZINC PL-REPLCS H#0080
19	6	00-0236-0003-00	WASHER, LK SAE STD MED 3/8" PL REPLCS H#0007
20	2	00-0215-0002-00	PNL SPRING, .125 DIA X 1.50 LG
21	2	00-2833-0003-00	NUT, HEX ESM3/8"-16NC-38
22	6	00-0204-0000-00	BOLT, SHOULDER, 1/2 X 3/8
23	4	00-6895-0001-00	COTTERLESS CLIP, .275 DIA X 1.500 GRIP
24	2	00-0567-0024-00	SPRING, EXTENSION SST WIRE
25	4	00-0823-0000-06	SCCS 5/16-18 X 3/4" ZINC PL REPLCS H-S0065 428-B01-3300-10
26	2	00-0203-0600-05	BOLT, HEX HD .375-16 X 5/8" SAE GRADE 5 - ZINC PLATED
27	1	28-8204-4210-20	SHAFT, PIVOT LOCKING
28	2	28-8204-7120-20	BOLT, CLAMP HANDLE SWING, 14M
29	1	28-8204-7920-30	SHORT HANDLE ASSEMBLY
30	1	28-8204-7930-30	LONG HANDLE ASSEMBLY
31	1	700060	NAMEPLATE, 14M, 130 VAC
32	2	00-2905-0300-03	SCREW, DR HD TYPE U #2 X 3/16
33	1	28-8204-6010-20	INSERT, A DIS X 4 IPS
34	2	00-0823-0600-10	SCCS 5/16-18 X 1-1/4" ZINC PL REPLCS H-S0062
35	2	00-0823-0600-08	SCCS 3/8-16 X 1" ZINC PL REPLCS H#0027 428-B001-4200-10
36	1	28-0204-7025-40	ASSY, STATIONARY CLAMP CF-148 FOR 14M W FO AFTER 2005
37	1	28-0204-7040-40	ASSY, SLIDING CLAMP CF-14
38	1	28-0204-7050-40	ASSY, TOP CLAMP CF-14

SIZE	MAIN ASSEMBLY USAGE				SUB-ASSEMBLY USED ON			
	10CQ	20CQ	10HP	20HP	QTY	ASSEMBLY	QTY	ASSEMBLY
4					40	28-0204-3020-40	1	28-0204-3020-40
8						28-0204-5040-40	1	28-0204-5040-40
14								
18								
24								
36								

UNLESS OTHERWISE NOTED SPECIFY:
 ALL DIMENSIONS ARE IN INCHES
 FINISHES:
 1/16" SURFACE
 1/8" SURFACE
 1/4" SURFACE
 3/16" SURFACE
 1/2" SURFACE
 5/8" SURFACE
 1" SURFACE
 1 1/2" SURFACE
 2" SURFACE
 3" SURFACE
 4" SURFACE
 5" SURFACE
 6" SURFACE
 8" SURFACE
 10" SURFACE
 12" SURFACE
 14" SURFACE
 16" SURFACE
 18" SURFACE
 20" SURFACE
 24" SURFACE
 30" SURFACE
 36" SURFACE

CONNECTICA®
 SERVICE DEPARTMENT
 JOINING ASSEMBLY, 14M

DATE: 09/19/07
 APPR: L. BROWN
 CHECKED: DATE: DATE:
 SHEET 1 OF 3

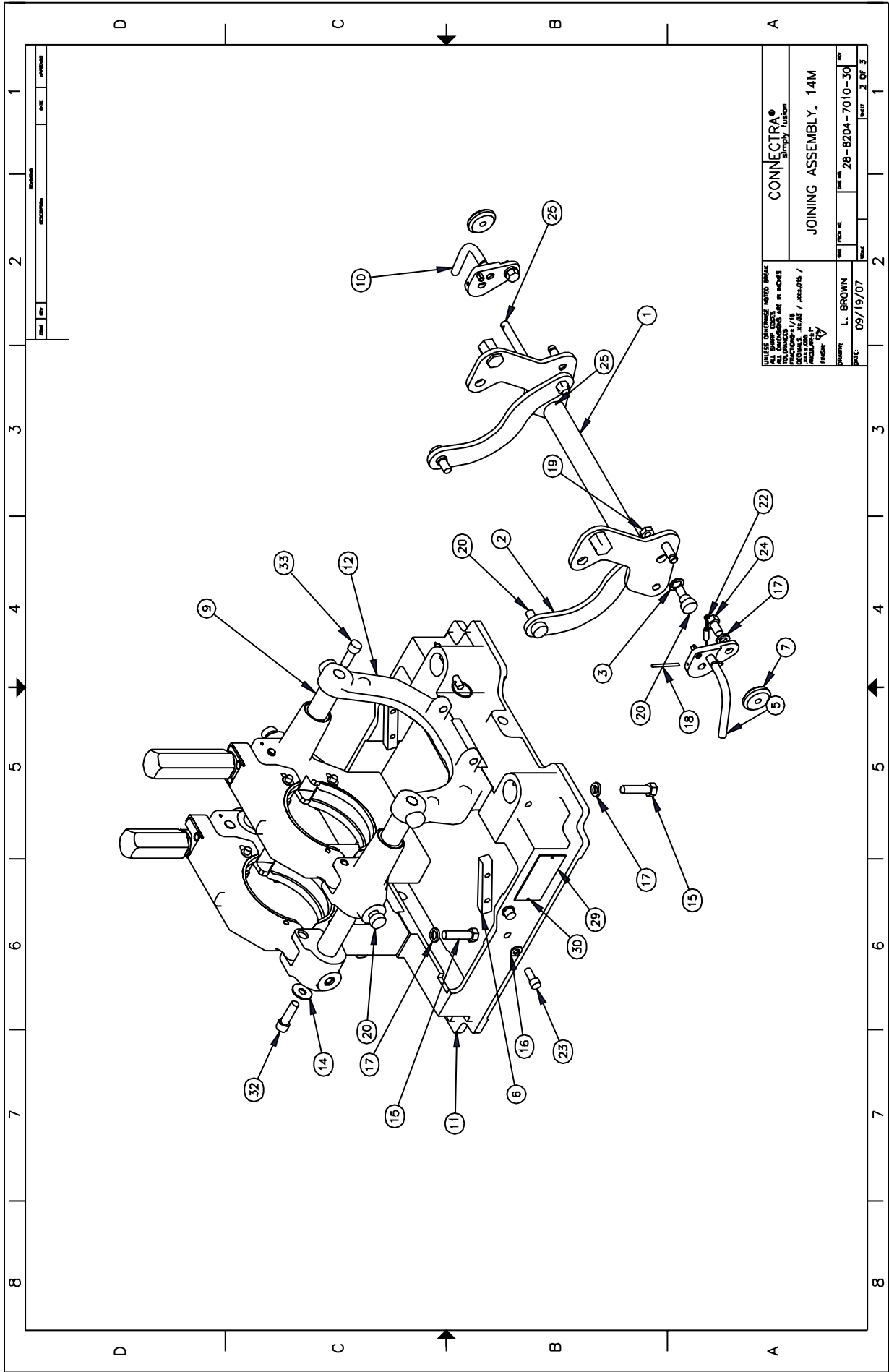

ALL DIMENSIONS UNLESS NOTED OTHERWISE
 ALL DIMENSIONS ARE IN INCHES
 FRACTIONS 1/8" / 16
 DECIMALS .001" / 1000
 UNLESS NOTED OTHERWISE
 UNLESS NOTED OTHERWISE

CONNECTRA
 Energy Fusion

JOINING ASSEMBLY, 14M

DESIGNER	L. BROWN	DATE	09/19/07
SCALE		FIG. NO.	28-8204-7010-30
		REV.	2 OF 3

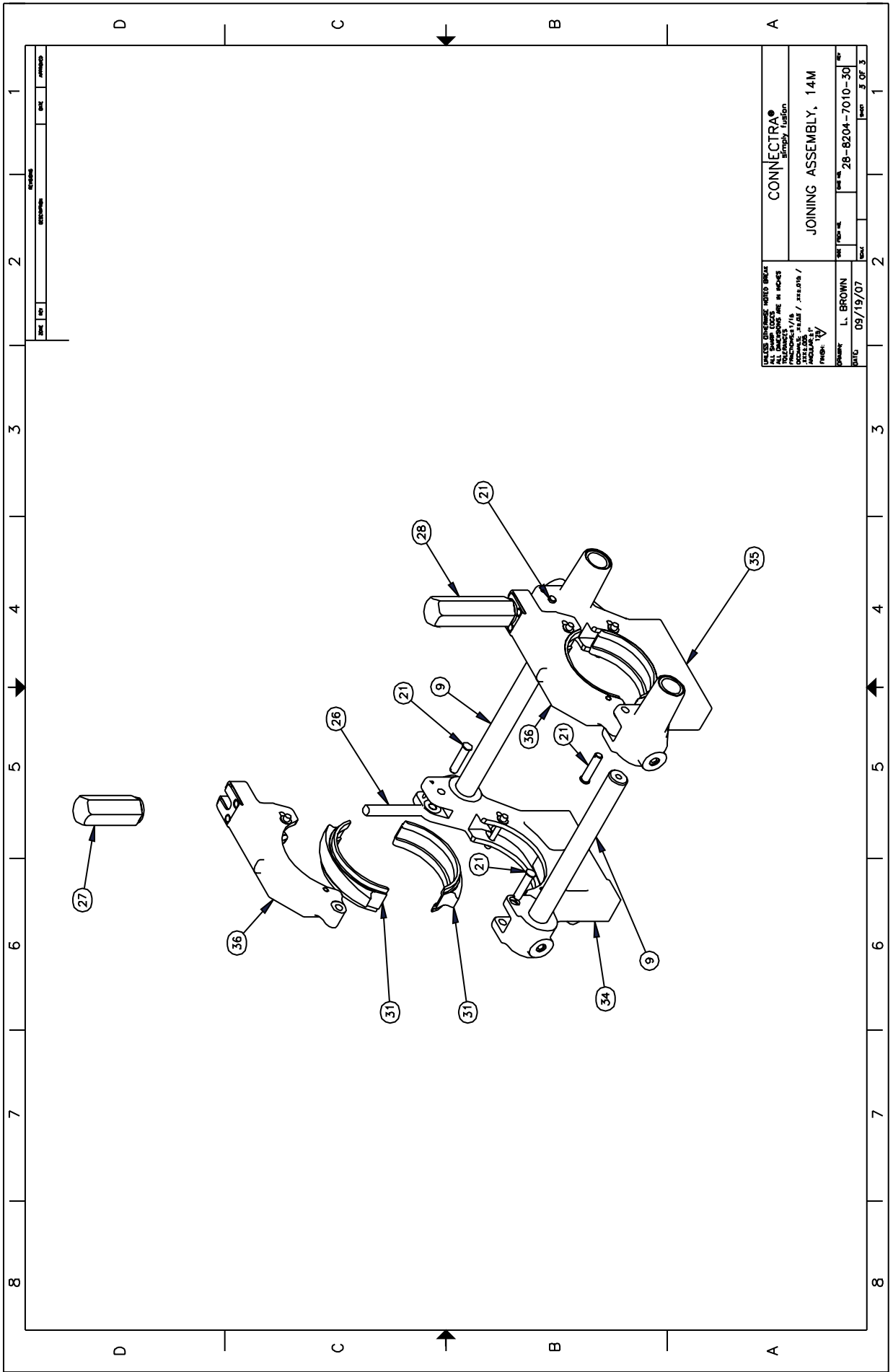

ALL DIMENSIONS UNLESS NOTED OTHERWISE ALL DIMENSIONS ARE IN INCHES FRACTIONS 1/8, 3/16, 1/4, 5/16, 3/8, 1/2, 5/8, 3/4, 7/8, 1, 1 1/8, 1 1/4, 1 1/2, 1 3/4, 2, 2 1/4, 2 1/2, 3, 3 1/4, 3 1/2, 4, 4 1/4, 4 1/2, 5, 5 1/4, 5 1/2, 6, 6 1/4, 6 1/2, 7, 7 1/4, 7 1/2, 8, 8 1/4, 8 1/2, 9, 9 1/4, 9 1/2, 10, 10 1/4, 10 1/2, 11, 11 1/4, 11 1/2, 12, 12 1/4, 12 1/2, 13, 13 1/4, 13 1/2, 14, 14 1/4, 14 1/2, 15, 15 1/4, 15 1/2, 16, 16 1/4, 16 1/2, 17, 17 1/4, 17 1/2, 18, 18 1/4, 18 1/2, 19, 19 1/4, 19 1/2, 20, 20 1/4, 20 1/2, 21, 21 1/4, 21 1/2, 22, 22 1/4, 22 1/2, 23, 23 1/4, 23 1/2, 24, 24 1/4, 24 1/2, 25, 25 1/4, 25 1/2, 26, 26 1/4, 26 1/2, 27, 27 1/4, 27 1/2, 28, 28 1/4, 28 1/2, 29, 29 1/4, 29 1/2, 30, 30 1/4, 30 1/2, 31, 31 1/4, 31 1/2, 32, 32 1/4, 32 1/2, 33, 33 1/4, 33 1/2, 34, 34 1/4, 34 1/2, 35, 35 1/4, 35 1/2, 36, 36 1/4, 36 1/2, 37, 37 1/4, 37 1/2, 38, 38 1/4, 38 1/2, 39, 39 1/4, 39 1/2, 40, 40 1/4, 40 1/2, 41, 41 1/4, 41 1/2, 42, 42 1/4, 42 1/2, 43, 43 1/4, 43 1/2, 44, 44 1/4, 44 1/2, 45, 45 1/4, 45 1/2, 46, 46 1/4, 46 1/2, 47, 47 1/4, 47 1/2, 48, 48 1/4, 48 1/2, 49, 49 1/4, 49 1/2, 50, 50 1/4, 50 1/2, 51, 51 1/4, 51 1/2, 52, 52 1/4, 52 1/2, 53, 53 1/4, 53 1/2, 54, 54 1/4, 54 1/2, 55, 55 1/4, 55 1/2, 56, 56 1/4, 56 1/2, 57, 57 1/4, 57 1/2, 58, 58 1/4, 58 1/2, 59, 59 1/4, 59 1/2, 60, 60 1/4, 60 1/2, 61, 61 1/4, 61 1/2, 62, 62 1/4, 62 1/2, 63, 63 1/4, 63 1/2, 64, 64 1/4, 64 1/2, 65, 65 1/4, 65 1/2, 66, 66 1/4, 66 1/2, 67, 67 1/4, 67 1/2, 68, 68 1/4, 68 1/2, 69, 69 1/4, 69 1/2, 70, 70 1/4, 70 1/2, 71, 71 1/4, 71 1/2, 72, 72 1/4, 72 1/2, 73, 73 1/4, 73 1/2, 74, 74 1/4, 74 1/2, 75, 75 1/4, 75 1/2, 76, 76 1/4, 76 1/2, 77, 77 1/4, 77 1/2, 78, 78 1/4, 78 1/2, 79, 79 1/4, 79 1/2, 80, 80 1/4, 80 1/2, 81, 81 1/4, 81 1/2, 82, 82 1/4, 82 1/2, 83, 83 1/4, 83 1/2, 84, 84 1/4, 84 1/2, 85, 85 1/4, 85 1/2, 86, 86 1/4, 86 1/2, 87, 87 1/4, 87 1/2, 88, 88 1/4, 88 1/2, 89, 89 1/4, 89 1/2, 90, 90 1/4, 90 1/2, 91, 91 1/4, 91 1/2, 92, 92 1/4, 92 1/2, 93, 93 1/4, 93 1/2, 94, 94 1/4, 94 1/2, 95, 95 1/4, 95 1/2, 96, 96 1/4, 96 1/2, 97, 97 1/4, 97 1/2, 98, 98 1/4, 98 1/2, 99, 99 1/4, 99 1/2, 100, 100 1/4, 100 1/2, 101, 101 1/4, 101 1/2, 102, 102 1/4, 102 1/2, 103, 103 1/4, 103 1/2, 104, 104 1/4, 104 1/2, 105, 105 1/4, 105 1/2, 106, 106 1/4, 106 1/2, 107, 107 1/4, 107 1/2, 108, 108 1/4, 108 1/2, 109, 109 1/4, 109 1/2, 110, 110 1/4, 110 1/2, 111, 111 1/4, 111 1/2, 112, 112 1/4, 112 1/2, 113, 113 1/4, 113 1/2, 114, 114 1/4, 114 1/2, 115, 115 1/4, 115 1/2, 116, 116 1/4, 116 1/2, 117, 117 1/4, 117 1/2, 118, 118 1/4, 118 1/2, 119, 119 1/4, 119 1/2, 120, 120 1/4, 120 1/2, 121, 121 1/4, 121 1/2, 122, 122 1/4, 122 1/2, 123, 123 1/4, 123 1/2, 124, 124 1/4, 124 1/2, 125, 125 1/4, 125 1/2, 126, 126 1/4, 126 1/2, 127, 127 1/4, 127 1/2, 128, 128 1/4, 128 1/2, 129, 129 1/4, 129 1/2, 130, 130 1/4, 130 1/2, 131, 131 1/4, 131 1/2, 132, 132 1/4, 132 1/2, 133, 133 1/4, 133 1/2, 134, 134 1/4, 134 1/2, 135, 135 1/4, 135 1/2, 136, 136 1/4, 136 1/2, 137, 137 1/4, 137 1/2, 138, 138 1/4, 138 1/2, 139, 139 1/4, 139 1/2, 140, 140 1/4, 140 1/2, 141, 141 1/4, 141 1/2, 142, 142 1/4, 142 1/2, 143, 143 1/4, 143 1/2, 144, 144 1/4, 144 1/2, 145, 145 1/4, 145 1/2, 146, 146 1/4, 146 1/2, 147, 147 1/4, 147 1/2, 148, 148 1/4, 148 1/2, 149, 149 1/4, 149 1/2, 150, 150 1/4, 150 1/2, 151, 151 1/4, 151 1/2, 152, 152 1/4, 152 1/2, 153, 153 1/4, 153 1/2, 154, 154 1/4, 154 1/2, 155, 155 1/4, 155 1/2, 156, 156 1/4, 156 1/2, 157, 157 1/4, 157 1/2, 158, 158 1/4, 158 1/2, 159, 159 1/4, 159 1/2, 160, 160 1/4, 160 1/2, 161, 161 1/4, 161 1/2, 162, 162 1/4, 162 1/2, 163, 163 1/4, 163 1/2, 164, 164 1/4, 164 1/2, 165, 165 1/4, 165 1/2, 166, 166 1/4, 166 1/2, 167, 167 1/4, 167 1/2, 168, 168 1/4, 168 1/2, 169, 169 1/4, 169 1/2, 170, 170 1/4, 170 1/2, 171, 171 1/4, 171 1/2, 172, 172 1/4, 172 1/2, 173, 173 1/4, 173 1/2, 174, 174 1/4, 174 1/2, 175, 175 1/4, 175 1/2, 176, 176 1/4, 176 1/2, 177, 177 1/4, 177 1/2, 178, 178 1/4, 178 1/2, 179, 179 1/4, 179 1/2, 180, 180 1/4, 180 1/2, 181, 181 1/4, 181 1/2, 182, 182 1/4, 182 1/2, 183, 183 1/4, 183 1/2, 184, 184 1/4, 184 1/2, 185, 185 1/4, 185 1/2, 186, 186 1/4, 186 1/2, 187, 187 1/4, 187 1/2, 188, 188 1/4, 188 1/2, 189, 189 1/4, 189 1/2, 190, 190 1/4, 190 1/2, 191, 191 1/4, 191 1/2, 192, 192 1/4, 192 1/2, 193, 193 1/4, 193 1/2, 194, 194 1/4, 194 1/2, 195, 195 1/4, 195 1/2, 196, 196 1/4, 196 1/2, 197, 197 1/4, 197 1/2, 198, 198 1/4, 198 1/2, 199, 199 1/4, 199 1/2, 200, 200 1/4, 200 1/2, 201, 201 1/4, 201 1/2, 202, 202 1/4, 202 1/2, 203, 203 1/4, 203 1/2, 204, 204 1/4, 204 1/2, 205, 205 1/4, 205 1/2, 206, 206 1/4, 206 1/2, 207, 207 1/4, 207 1/2, 208, 208 1/4, 208 1/2, 209, 209 1/4, 209 1/2, 210, 210 1/4, 210 1/2, 211, 211 1/4, 211 1/2, 212, 212 1/4, 212 1/2, 213, 213 1/4, 213 1/2, 214, 214 1/4, 214 1/2, 215, 215 1/4, 215 1/2, 216, 216 1/4, 216 1/2, 217, 217 1/4, 217 1/2, 218, 218 1/4, 218 1/2, 219, 219 1/4, 219 1/2, 220, 220 1/4, 220 1/2, 221, 221 1/4, 221 1/2, 222, 222 1/4, 222 1/2, 223, 223 1/4, 223 1/2, 224, 224 1/4, 224 1/2, 225, 225 1/4, 225 1/2, 226, 226 1/4, 226 1/2, 227, 227 1/4, 227 1/2, 228, 228 1/4, 228 1/2, 229, 229 1/4, 229 1/2, 230, 230 1/4, 230 1/2, 231, 231 1/4, 231 1/2, 232, 232 1/4, 232 1/2, 233, 233 1/4, 233 1/2, 234, 234 1/4, 234 1/2, 235, 235 1/4, 235 1/2, 236, 236 1/4, 236 1/2, 237, 237 1/4, 237 1/2, 238, 238 1/4, 238 1/2, 239, 239 1/4, 239 1/2, 240, 240 1/4, 240 1/2, 241, 241 1/4, 241 1/2, 242, 242 1/4, 242 1/2, 243, 243 1/4, 243 1/2, 244, 244 1/4, 244 1/2, 245, 245 1/4, 245 1/2, 246, 246 1/4, 246 1/2, 247, 247 1/4, 247 1/2, 248, 248 1/4, 248 1/2, 249, 249 1/4, 249 1/2, 250, 250 1/4, 250 1/2, 251, 251 1/4, 251 1/2, 252, 252 1/4, 252 1/2, 253, 253 1/4, 253 1/2, 254, 254 1/4, 254 1/2, 255, 255 1/4, 255 1/2, 256, 256 1/4, 256 1/2, 257, 257 1/4, 257 1/2, 258, 258 1/4, 258 1/2, 259, 259 1/4, 259 1/2, 260, 260 1/4, 260 1/2, 261, 261 1/4, 261 1/2, 262, 262 1/4, 262 1/2, 263, 263 1/4, 263 1/2, 264, 264 1/4, 264 1/2, 265, 265 1/4, 265 1/2, 266, 266 1/4, 266 1/2, 267, 267 1/4, 267 1/2, 268, 268 1/4, 268 1/2, 269, 269 1/4, 269 1/2, 270, 270 1/4, 270 1/2, 271, 271 1/4, 271 1/2, 272, 272 1/4, 272 1/2, 273, 273 1/4, 273 1/2, 274, 274 1/4, 274 1/2, 275, 275 1/4, 275 1/2, 276, 276 1/4, 276 1/2, 277, 277 1/4, 277 1/2, 278, 278 1/4, 278 1/2, 279, 279 1/4, 279 1/2, 280, 280 1/4, 280 1/2, 281, 281 1/4, 281 1/2, 282, 282 1/4, 282 1/2, 283, 283 1/4, 283 1/2, 284, 284 1/4, 284 1/2, 285, 285 1/4, 285 1/2, 286, 286 1/4, 286 1/2, 287, 287 1/4, 287 1/2, 288, 288 1/4, 288 1/2, 289, 289 1/4, 289 1/2, 290, 290 1/4, 290 1/2, 291, 291 1/4, 291 1/2, 292, 292 1/4, 292 1/2, 293, 293 1/4, 293 1/2, 294, 294 1/4, 294 1/2, 295, 295 1/4, 295 1/2, 296, 296 1/4, 296 1/2, 297, 297 1/4, 297 1/2, 298, 298 1/4, 298 1/2, 299, 299 1/4, 299 1/2, 300, 300 1/4, 300 1/2, 301, 301 1/4, 301 1/2, 302, 302 1/4, 302 1/2, 303, 303 1/4, 303 1/2, 304, 304 1/4, 304 1/2, 305, 305 1/4, 305 1/2, 306, 306 1/4, 306 1/2, 307, 307 1/4, 307 1/2, 308, 308 1/4, 308 1/2, 309, 309 1/4, 309 1/2, 310, 310 1/4, 310 1/2, 311, 311 1/4, 311 1/2, 312, 312 1/4, 312 1/2, 313, 313 1/4, 313 1/2, 314, 314 1/4, 314 1/2, 315, 315 1/4, 315 1/2, 316, 316 1/4, 316 1/2, 317, 317 1/4, 317 1/2, 318, 318 1/4, 318 1/2, 319, 319 1/4, 319 1/2, 320, 320 1/4, 320 1/2, 321, 321 1/4, 321 1/2, 322, 322 1/4, 322 1/2, 323, 323 1/4, 323 1/2, 324, 324 1/4, 324 1/2, 325, 325 1/4, 325 1/2, 326, 326 1/4, 326 1/2, 327, 327 1/4, 327 1/2, 328, 328 1/4, 328 1/2, 329, 329 1/4, 329 1/2, 330, 330 1/4, 330 1/2, 331, 331 1/4, 331 1/2, 332, 332 1/4, 332 1/2, 333, 333 1/4, 333 1/2, 334, 334 1/4, 334 1/2, 335, 335 1/4, 335 1/2, 336, 336 1/4, 336 1/2, 337, 337 1/4, 337 1/2, 338, 338 1/4, 338 1/2, 339, 339 1/4, 339 1/2, 340, 340 1/4, 340 1/2, 341, 341 1/4, 341 1/2, 342, 342 1/4, 342 1/2, 343, 343 1/4, 343 1/2, 344, 344 1/4, 344 1/2, 345, 345 1/4, 345 1/2, 346, 346 1/4, 346 1/2, 347, 347 1/4, 347 1/2, 348, 348 1/4, 348 1/2, 349, 349 1/4, 349 1/2, 350, 350 1/4, 350 1/2, 351, 351 1/4, 351 1/2, 352, 352 1/4, 352 1/2, 353, 353 1/4, 353 1/2, 354, 354 1/4, 354 1/2, 355, 355 1/4, 355 1/2, 356, 356 1/4, 356 1/2, 357, 357 1/4, 357 1/2, 358, 358 1/4, 358 1/2, 359, 359 1/4, 359 1/2, 360, 360 1/4, 360 1/2, 361, 361 1/4, 361 1/2, 362, 362 1/4, 362 1/2, 363, 363 1/4, 363 1/2, 364, 364 1/4, 364 1/2, 365, 365 1/4, 365 1/2, 366, 366 1/4, 366 1/2, 367, 367 1/4, 367 1/2, 368, 368 1/4, 368 1/2, 369, 369 1/4, 369 1/2, 370, 370 1/4, 370 1/2, 371, 371 1/4, 371 1/2, 372, 372 1/4, 372 1/2, 373, 373 1/4, 373 1/2, 374, 374 1/4, 374 1/2, 375, 375 1/4, 375 1/2, 376, 376 1/4, 376 1/2, 377, 377 1/4, 377 1/2, 378, 378 1/4, 378 1/2, 379, 379 1/4, 379 1/2, 380, 380 1/4, 380 1/2, 381, 381 1/4, 381 1/2, 382, 382 1/4, 382 1/2, 383, 383 1/4, 383 1/2, 384, 384 1/4, 384 1/2, 385, 385 1/4, 385 1/2, 386, 386 1/4, 386 1/2, 387, 387 1/4, 387 1/2, 388, 388 1/4, 388 1/2, 389, 389 1/4, 389 1/2, 390, 390 1/4, 390 1/2, 391, 391 1/4, 391 1/2, 392, 392 1/4, 392 1/2, 393, 393 1/4, 393 1/2, 394, 394 1/4, 394 1/2, 395, 395 1/4, 395 1/2, 396, 396 1/4, 396 1/2, 397, 397 1/4, 397 1/2, 398, 398 1/4, 398 1/2, 399, 399 1/4, 399 1/2, 400, 400 1/4, 400 1/2, 401, 401 1/4, 401 1/2, 402, 402 1/4, 402 1/2, 403, 403 1/4, 403 1/2, 404, 404 1/4, 404 1/2, 405, 405 1/4, 405 1/2, 406, 406 1/4, 406 1/2, 407, 407 1/4, 407 1/2, 408, 408 1/4, 408 1/2, 409, 409 1/4, 409 1/2, 410, 410 1/4, 410 1/2, 411, 411 1/4, 411 1/2, 412, 412 1/4, 412 1/2, 413, 413 1/4, 413 1/2, 414, 414 1/4, 414 1/2, 415, 415 1/4, 415 1/2, 416, 416 1/4, 416 1/2, 417, 417 1/4, 417 1/2, 418, 418 1/4, 418 1/2, 419, 419 1/4, 419 1/2, 420, 420 1/4, 420 1/2, 421, 421 1/4, 421 1/2, 422, 422 1/4, 422 1/2, 423, 423 1/4, 423 1/2, 424, 424 1/4, 424 1/2, 425, 425 1/4, 425 1/2, 426, 426 1/4, 426 1/2, 427, 427 1/4, 427 1/2, 428, 428 1/4, 428 1/2, 429, 429 1/4, 429 1/2, 430, 430 1/4, 430 1/2, 431, 431 1/4, 431 1/2, 432, 432 1/4, 432 1/2, 433, 433 1/4, 433 1/2, 434, 434 1/4, 434 1/2, 435, 435 1/4, 435 1/2, 436, 436 1/4, 436 1/2, 437, 437 1/4, 437 1/2, 438, 438 1/4, 438 1/2, 439, 439 1/4, 439 1/2, 440, 440 1/4, 440 1/2, 441, 441 1/4, 441 1/2, 442, 442 1/4, 442 1/2, 443, 443 1/4, 443 1/2, 444, 444 1/4, 444 1/2, 445, 445 1/4, 445 1/2, 446, 446 1/4, 446 1/2, 447, 447 1/4, 447 1/2, 448, 448 1/4, 448 1/2, 449, 449 1/4, 449 1/2, 450, 450 1/4, 450 1/2, 451, 451 1/4, 451 1/2, 452, 452 1/4, 452 1/2, 453, 453 1/4, 453 1/2, 454, 454 1/4, 454 1/2, 455, 455 1/4, 455 1/2, 456, 456 1/4, 456 1/2, 457, 457 1/4, 457 1/2, 458, 458 1/4, 458 1/2, 459, 459 1/4, 459 1/2, 460, 460 1/4, 460 1/2, 461, 461 1/4, 461 1/2, 462, 462 1/4, 462 1/2, 463, 463 1/4, 463 1/2, 464, 464 1/4, 464 1/2, 465, 465 1/4, 465 1/2, 466, 466 1/4, 466 1/2, 467, 467 1/4, 467 1/2, 468, 468 1/4, 468 1/2, 469, 469 1/4, 469 1/2, 470, 470 1/4, 470 1/2, 471, 471 1/4, 471 1/2, 472, 472 1/4, 472 1/2, 473, 473 1/4, 473 1/2, 474, 474 1/4, 474 1/2, 475, 475 1/4, 475 1/2, 476, 476 1/4, 476 1/2, 477, 477 1/4, 477 1/2, 478, 478 1/4, 478 1/2, 479, 479 1/4, 479 1/2, 480, 480 1/4, 480 1/2, 481, 481 1/4, 481 1/2, 482, 482 1/4, 482 1/2, 483, 483 1/4, 483 1/2, 484, 484 1/4, 484 1/2, 485, 485 1/4, 485 1/2, 486, 486 1/4, 486 1/2, 487, 487 1/4, 487 1/2, 488, 488 1/4, 488 1/2, 489, 489 1/4, 489 1/2, 490, 490 1/4, 490 1/2, 491, 491 1/4, 491 1/2, 492, 492 1/4, 492 1/2, 493, 493 1/4, 493 1/2, 494, 494 1/4, 494 1/2, 495, 495 1/4, 495 1/2, 496, 496 1/4, 496 1/2, 497, 497 1/4, 497 1/2, 498, 498 1/4, 498 1/2, 499, 499 1/4, 499 1/2, 500, 500 1/4, 500 1/2, 501, 501 1/4, 501 1/2, 502, 502 1/4, 502 1/2, 503, 503 1/4, 503 1/2, 504, 504 1/4, 504 1/2, 505, 505 1/4, 505 1/2, 506, 506 1/4, 506 1/2, 507, 507 1/4, 507 1/2, 508, 508 1/4, 508 1/2, 509, 509 1/4, 509 1/2, 510, 510 1/4, 510 1/2, 511, 511 1/4, 511 1/2, 512, 512 1/4, 512 1/2, 513, 513 1/4, 513 1/2, 514, 514 1/4, 514 1/2, 515, 515 1/4, 515 1/2, 516, 516 1/4, 516 1/2, 517, 517 1/4, 517 1/2, 518, 518 1/4, 518 1/2, 519, 519 1/4, 519 1/2, 520, 520 1/4, 520 1/2, 521, 521 1/4, 521 1/2, 522, 522 1/4, 522 1/2, 523, 523 1/4, 523 1/2, 524, 524 1/4, 524 1/2, 525, 525 1/4, 525 1/2, 526, 526 1/4, 526 1/2, 527, 527 1/4, 527 1/2, 528, 528 1/4, 528 1/2, 529, 529 1/4, 529 1/2, 530, 530 1/4, 530 1/2, 531, 531 1/4, 531 1/2, 532, 532 1/4, 532 1/2, 533, 533 1/4, 533 1/2, 534, 534 1/4, 534 1/2, 535, 535 1/4, 535 1/2, 536, 536 1/4,	
--------------------------------------------------------------------------------------------------------------------------------------------------------------------------------------------------------------------------------------------------------------------------------------------------------------------------------------------------------------------------------------------------------------------------------------------------------------------------------------------------------------------------------------------------------------------------------------------------------------------------------------------------------------------------------------------------------------------------------------------------------------------------------------------------------------------------------------------------------------------------------------------------------------------------------------------------------------------------------------------------------------------------------------------------------------------------------------------------------------------------------------------------------------------------------------------------------------------------------------------------------------------------------------------------------------------------------------------------------------------------------------------------------------------------------------------------------------------------------------------------------------------------------------------------------------------------------------------------------------------------------------------------------------------------------------------------------------------------------------------------------------------------------------------------------------------------------------------------------------------------------------------------------------------------------------------------------------------------------------------------------------------------------------------------------------------------------------------------------------------------------------------------------------------------------------------------------------------------------------------------------------------------------------------------------------------------------------------------------------------------------------------------------------------------------------------------------------------------------------------------------------------------------------------------------------------------------------------------------------------------------------------------------------------------------------------------------------------------------------------------------------------------------------------------------------------------------------------------------------------------------------------------------------------------------------------------------------------------------------------------------------------------------------------------------------------------------------------------------------------------------------------------------------------------------------------------------------------------------------------------------------------------------------------------------------------------------------------------------------------------------------------------------------------------------------------------------------------------------------------------------------------------------------------------------------------------------------------------------------------------------------------------------------------------------------------------------------------------------------------------------------------------------------------------------------------------------------------------------------------------------------------------------------------------------------------------------------------------------------------------------------------------------------------------------------------------------------------------------------------------------------------------------------------------------------------------------------------------------------------------------------------------------------------------------------------------------------------------------------------------------------------------------------------------------------------------------------------------------------------------------------------------------------------------------------------------------------------------------------------------------------------------------------------------------------------------------------------------------------------------------------------------------------------------------------------------------------------------------------------------------------------------------------------------------------------------------------------------------------------------------------------------------------------------------------------------------------------------------------------------------------------------------------------------------------------------------------------------------------------------------------------------------------------------------------------------------------------------------------------------------------------------------------------------------------------------------------------------------------------------------------------------------------------------------------------------------------------------------------------------------------------------------------------------------------------------------------------------------------------------------------------------------------------------------------------------------------------------------------------------------------------------------------------------------------------------------------------------------------------------------------------------------------------------------------------------------------------------------------------------------------------------------------------------------------------------------------------------------------------------------------------------------------------------------------------------------------------------------------------------------------------------------------------------------------------------------------------------------------------------------------------------------------------------------------------------------------------------------------------------------------------------------------------------------------------------------------------------------------------------------------------------------------------------------------------------------------------------------------------------------------------------------------------------------------------------------------------------------------------------------------------------------------------------------------------------------------------------------------------------------------------------------------------------------------------------------------------------------------------------------------------------------------------------------------------------------------------------------------------------------------------------------------------------------------------------------------------------------------------------------------------------------------------------------------------------------------------------------------------------------------------------------------------------------------------------------------------------------------------------------------------------------------------------------------------------------------------------------------------------------------------------------------------------------------------------------------------------------------------------------------------------------------------------------------------------------------------------------------------------------------------------------------------------------------------------------------------------------------------------------------------------------------------------------------------------------------------------------------------------------------------------------------------------------------------------------------------------------------------------------------------------------------------------------------------------------------------------------------------------------------------------------------------------------------------------------------------------------------------------------------------------------------------------------------------------------------------------------------------------------------------------------------------------------------------------------------------------------------------------------------------------------------------------------------------------------------------------------------------------------------------------------------------------------------------------------------------------------------------------------------------------------------------------------------------------------------------------------------------------------------------------------------------------------------------------------------------------------------------------------------------------------------------------------------------------------------------------------------------------------------------------------------------------------------------------------------------------------------------------------------------------------------------------------------------------------------------------------------------------------------------------------------------------------------------------------------------------------------------------------------------------------------------------------------------------------------------------------------------------------------------------------------------------------------------------------------------------------------------------------------------------------------------------------------------------------------------------------------------------------------------------------------------------------------------------------------------------------------------------------------------------------------------------------------------------------------------------------------------------------------------------------------------------------------------------------------------------------------------------------------------------------------------------------------------------------------------------------------------------------------------------------------------------------------------------------------------------------------------------------------------------------------------------------------------------------------------------------------------------------------------------------------------------------------------------------------------------------------------------------------------------------------------------------------------------------------------------------------------------------------------------------------------------------------------------------------------------------------------------------------------------------------------------------------------------------------------------------------------------------------------------------------------------------------------------------------------------------------------------------------------------------------------------------------------------------------------------------------------------------------------------------------------------------------------------------------------------------------------------------------------------------------------------------------------------------------------------------------------------------------------------------------------------------------------------------------------------------------------------------------------------------------------------------------------------------------------------------------------------------------------------------------------------------------------------------------------------------------------------------------------------------------------------------------------------------------------------------------------------------------------	--

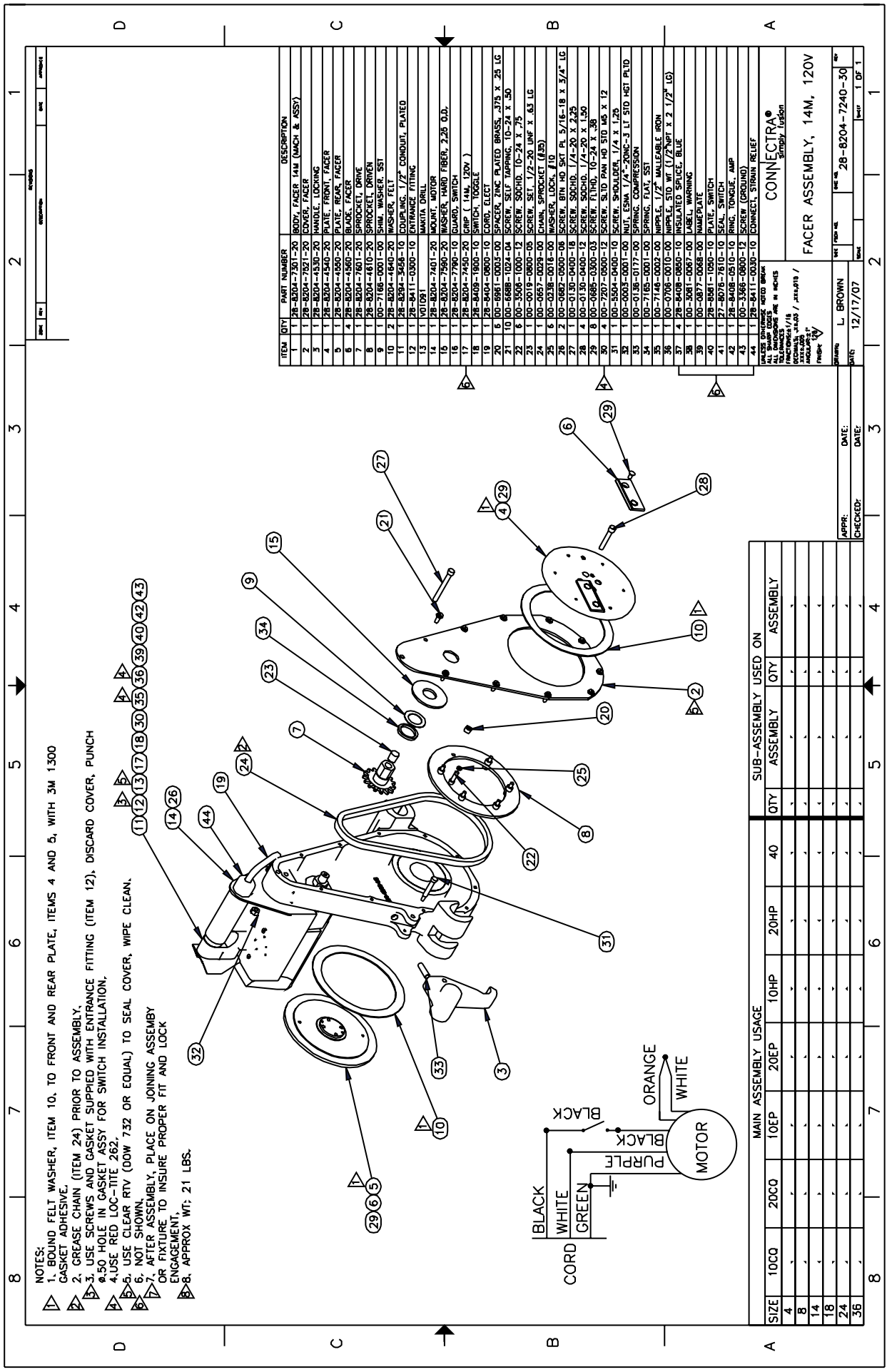

- NOTES:
- 1. BOUND FELT WASHER, ITEM 10, TO FRONT AND REAR PLATE, ITEMS 4 AND 5, WITH 3M 1300 GASKET ADHESIVE.
 - 2. GREASE CHAIN (ITEM 24) PRIOR TO ASSEMBLY.
 - 3. USE SCREWS AND GASKET SUPPLIED WITH ENTRANCE FITTING (ITEM 12). DISCARD COVER, PUNCH #.50 HOLE IN GASKET ASSY FOR SWITCH INSTALLATION.
 - 4. USE RED LOC-TITE 262.
 - 5. USE CLEAR RTV (DOW 732 OR EQUAL) TO SEAL COVER, WIPE CLEAN.
 - 6. NOT SHOWN.
 - 7. AFTER ASSEMBLY, PLACE ON JOINING ASSEMBY OR FIXTURE TO INSURE PROPER FIT AND LOCK ENGAGEMENT.
 - 8. APPROX. WT: 21 LBS.

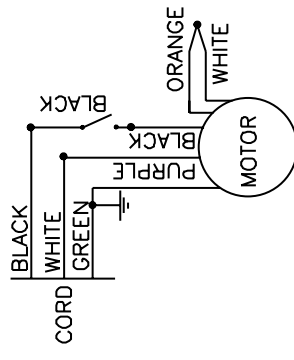

MAIN ASSEMBLY USAGE		SUB-ASSEMBLY USED ON							
SIZE	QTY	100C	200C	10HP	20HP	40	QTY	ASSEMBLY	ASSEMBLY
4	-	-	-	-	-	40	-	-	-
8	-	-	-	-	-	-	-	-	-
14	-	-	-	-	-	-	-	-	-
18	-	-	-	-	-	-	-	-	-
24	-	-	-	-	-	-	-	-	-
36	-	-	-	-	-	-	-	-	-

ITEM	QTY	PART NUMBER	DESCRIPTION
1	1	28-8204-7501-20	BODY, FACER 14M (MACH & ASSY)
2	1	28-8204-7501-20	COVER, FACER
3	1	28-8204-4330-20	HANDLE, LOCKING
4	1	28-8204-4500-20	PLATE, FRONT, FACER
5	1	28-8204-4500-20	PLATE, REAR, FACER
6	4	28-8204-4500-20	BACK, FACER
7	1	28-8204-4410-20	BRACKET DRIVE
8	1	100-7168-0001-20	SHAFT WASHER SST
9	1	100-7168-0001-20	WASHER, FELT
10	2	28-8204-4640-20	ENTRANCE FITTING
11	1	28-8204-3468-10	COUPLER 1/2" CONDUIT, PLATED
12	1	101091	MARKIA DRILL
13	1	28-8204-7401-20	MOUNT, MOTOR
14	1	28-8204-7500-20	WASHER, HARD FIBER, 2.25 O.D.
15	1	28-8204-7790-10	GUARD, SWITCH
16	1	28-8204-7450-20	CRIP (14M, 120V)
17	1	28-8409-1900-10	SWITCH, TOGGLE
18	1	28-8404-0600-10	CORD, ELECT
19	1	100-9981-0003-00	SPACER, ZINC PLATED BRASS, .375 X .25 LG
20	6	100-9981-0003-00	SCREW, SELF DRIPPING, 10-24 X .50
21	10	100-9981-0003-00	SCREW, SELF DRIPPING, 10-24 X .50
22	6	100-9981-0003-00	SCREW, SELF DRIPPING, 10-24 X .50
23	6	100-9981-0003-00	SCREW, SELF DRIPPING, 10-24 X .50
24	1	100-0652-0039-00	SCREW, SET, 1/2-20 UNF X .63 LG
25	6	100-0318-0016-00	WASHER, LOCK, 1/2
26	2	100-0682-0000-08	SCREW, BIN HD SRT PL, 5/16-18 X 3/4" LG
27	1	100-0130-0400-18	SCREW, SOCHD, 1/4-20 X 2.25
28	4	100-0130-0400-12	SCREW, SOCHD, 1/4-20 X 1.50
29	8	100-0688-0300-03	SCREW, FILHD, 10-24 X .38
30	4	100-2207-0000-12	SCREW, SLID PAN HD 510 MS X 12
31	1	100-8504-0400-10	SCREW, SHOULDER, 1/4 X 1.25
32	1	100-0003-0001-00	NUT, ESM, 1/4-20NC-3 LT STD HGT PLTD
33	1	100-0138-0177-00	SPRING, COMPRESSION
34	1	100-7168-0001-00	SPRING, FLAT, SST
35	1	100-7168-0002-00	SPRING, FLAT, SST
36	1	100-7168-0002-00	SPRING, FLAT, SST
37	1	100-7168-0002-00	SPRING, FLAT, SST
38	1	100-7168-0002-00	SPRING, FLAT, SST
39	1	100-7168-0002-00	SPRING, FLAT, SST
40	1	28-8408-0510-10	RING, TONGUE, AMP
41	1	28-8408-0510-10	RING, TONGUE, AMP
42	1	100-3368-0000-12	SCREW (GROUND)
43	1	100-3368-0000-12	SCREW (GROUND)
44	1	28-8411-0030-10	CONNECT, STRAIN RELIEF

CONNECTRA[®]
SINGLEY US80N

FACER ASSEMBLY, 14M, 120V

DATE: 12/17/07

APPROV: L. BROWN

CHECKED: _____

REV: 12/17/07

REV: 28-8204-7240-30

REV: 1 OF 1

- NOTES:
1. WRAP WIRE WITH #22 FIBERGLASS TAPE MAKING SURE SLEEVES ARE IN PLACE OVER CONNECTORS.
 2. SET TEMPERATURE AT 450° F.
 3. STAMP "120V-1500 WATT A/C" ON ONE SIDE OF HEATER BODY AND SERIAL NUMBER, DATE (MO/YR) AND THE TDW LOGO ON THE OTHER SIDE.
 4. MAKE FROM THERMOSWITCH CUT OFF.

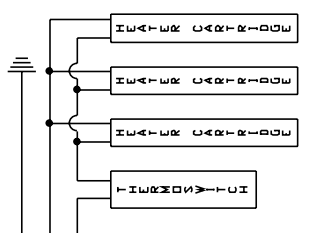
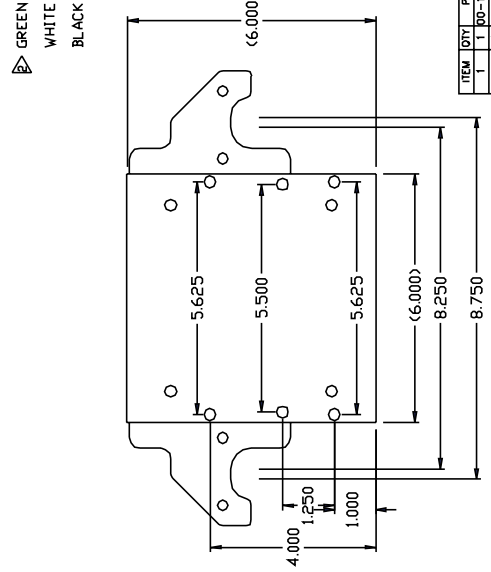
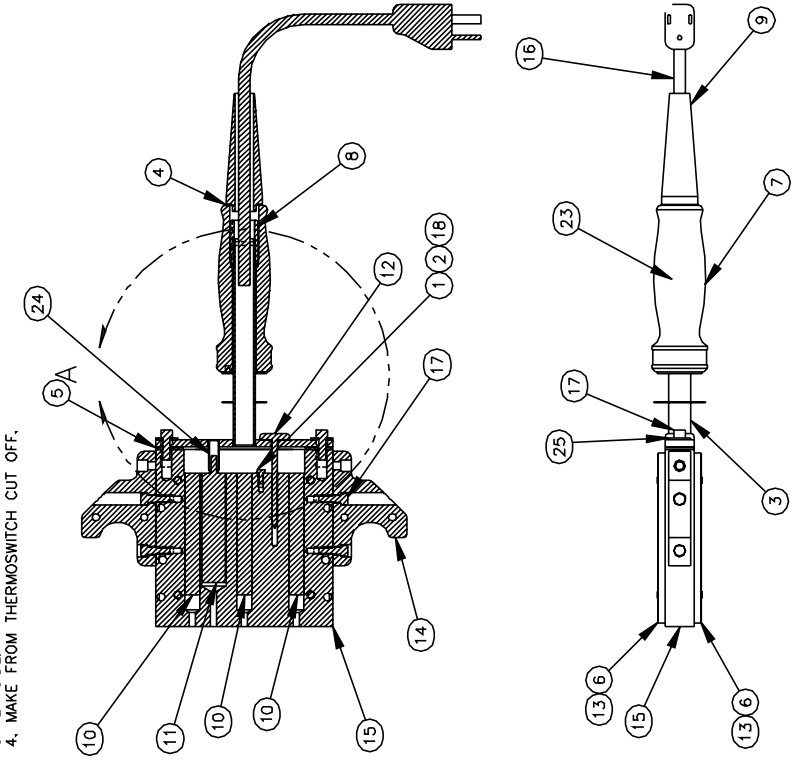

ITEM	QTY	PART NUMBER	DESCRIPTION
1	1	100-1300-0005-00	WASHER, 1/8" STAR
2	1	100-3365-0800-12	SCREW, #10, #2 X .375" LG
3	1	28-8204-7880-20	HANDLE, 14M HEATER
4	1	28-8153-0100-10	WASHER, HEATER HANDLE, 10-3
5	1	28-8153-3060-10	GASKET, HEATER, 10-3
6	2	28-8153-3070-20	PLATE, BUTT FUSION HEATER, 10-3
7	1	28-8153-3080-10	HANDLE, 10-3 HEATER
8	1	28-8153-3090-20	COUPLING, HEATER HANDLE, 10-3
9	1	28-8153-4070-10	FLEX FITTING
10	3	28-8401-0550-10	HEATER CARTRIDGE, 120V, 500W-.5 X 4.00
11	1	100169	THERMOSWITCH, LARGE, 17052-0
12	1	28-8559-0300-10	THERMOSWITCH, LARGE, 17052-0
13	4	100-0885-0400-12	SCREW, FILHD, 1/4"-20 X 1.50
14	2	28-8153-5000-20	GR. HEATER
15	1	28-8153-6000-10	CORD SET (1/2") W/ UNGROD PLUG
16	1	28-8153-6000-10	CORD SET (1/2") W/ UNGROD PLUG
17	6	100-0823-0400-08	WASHER, 1/8" STAR, #2 X .375" LG
18	1	28-8408-0510-10	EYELET
19	1	28-8408-0100-10	CONNECTOR, 10-12 GA
20	3	28-8408-0300-10	CONNECTOR, 14-16 GA
21	1	28-8412-0100-10	SLEEVE, INSULATING
22	1	28-8412-0400-14	TAPE, FIBERGLASS (24")
23	1	28-8123-1800-10	LABEL, WARNING
24	1	28-8213-1010-10	SHIELD, ADJUSTMENT
25	2	100-0435-0002-00	WASHER, FL STD SAE PL 1/4" REPLCS

MAIN ASSEMBLY USAGE		SUB-ASSEMBLY USED ON	
SIZE	QTY	ASSEMBLY	QTY
1	1	28-0204-3020-40	1
8	1		
14			
18			
24			
36			

26 1 100-3799-0163-00 INSTRUCTIONS (NOT SHOWN)

CONNECTRA FUSION TECHNOLOGIES, LLC

14M HEATER ASSEMBLY 120 VAC

DATE: 02/17/05

APPR: D.L. WEST

CHECKER:

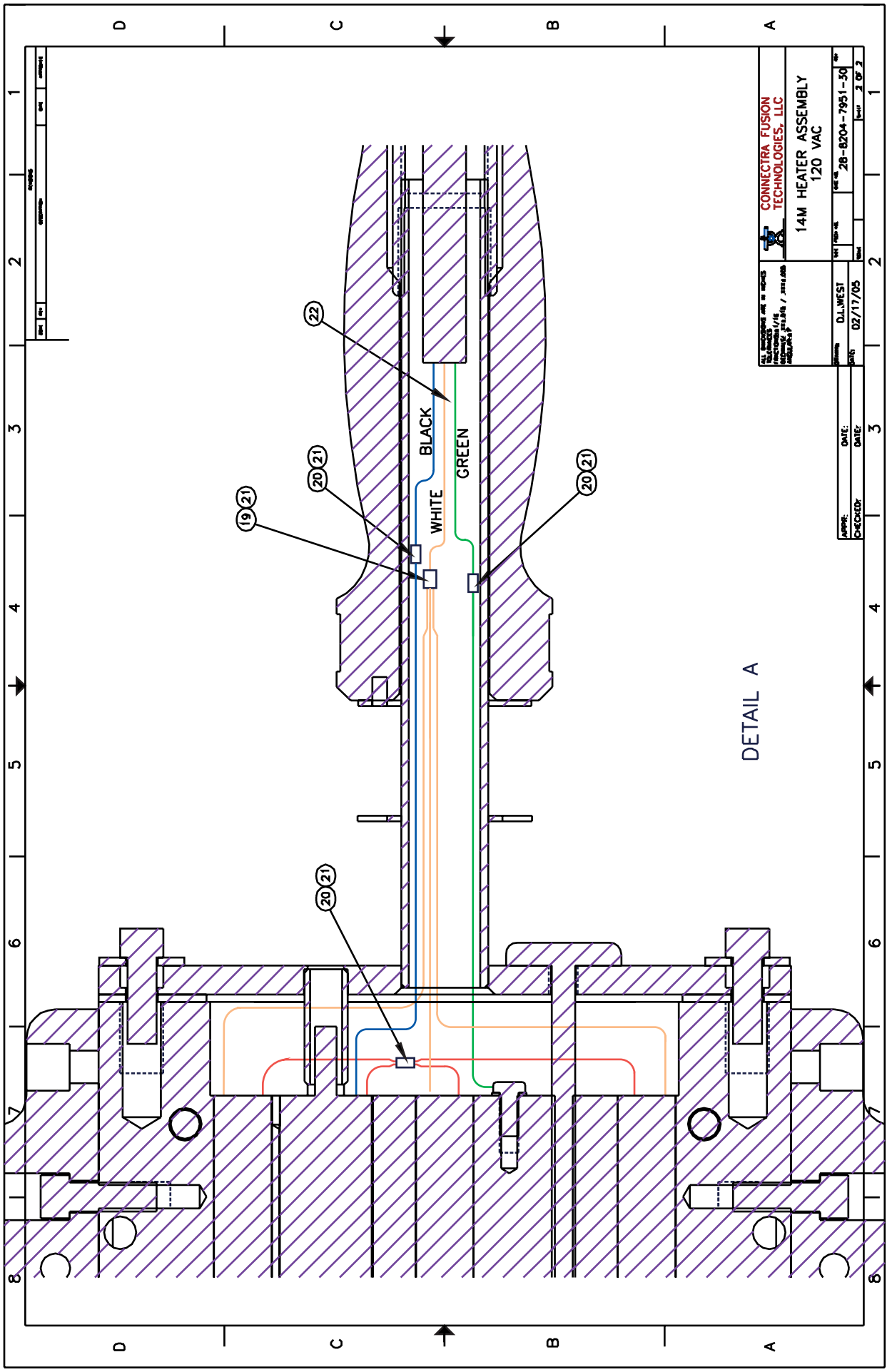

DETAIL A

 CONNECTRA FUSION TECHNOLOGIES, LLC		14M HEATER ASSEMBLY 120 VAC	
14 BROADWAY AVE. SUITE 200 WESTPORT, MA 01886 TEL: 978.335.8100 / 978.335.8101	DATE: 02/17/05 CHECKED BY:	REV. NO. 28-8204-7951-30 REV. 3 OF 2	DATE:

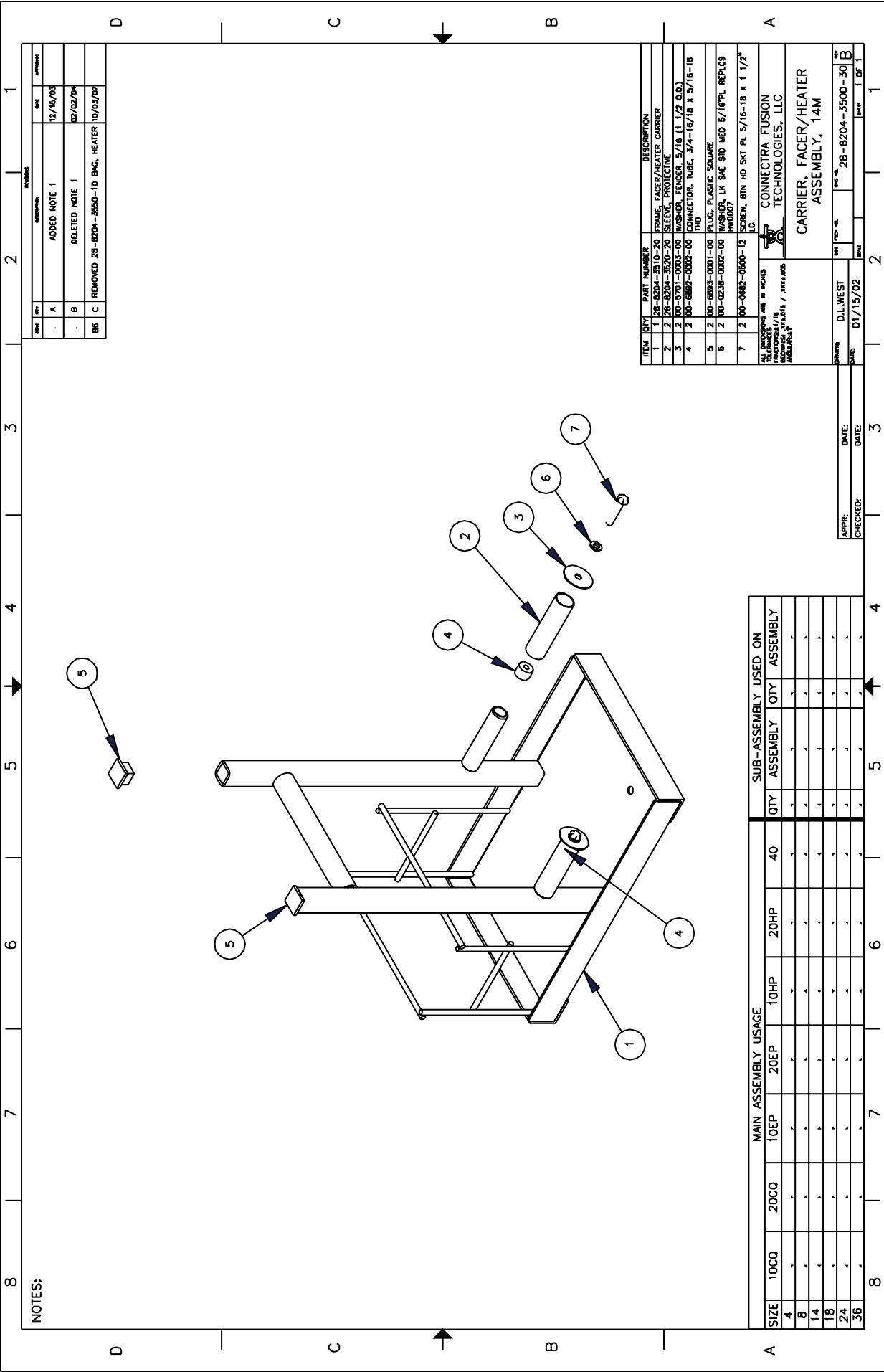

NOTES:

REV	DESCRIPTION	DATE	APPROVAL
A	ADDED NOTE 1	12/15/03	
B	DELETED NOTE 1	02/02/04	
C	REMOVED 28-8204-10 BAG, HEATER	10/03/07	

ITEM	QTY	PART NUMBER	DESCRIPTION
1	1	28-8204-3510-20	FRAME, FACER/HEATER CARRIER
2	2	28-8204-3520-20	SLEEVE, PROTECTIVE
3	2	00-0701-0003-00	WASHER, FENDER, 5/16 (L 1/2 O.D.)
4	2	00-6682-0002-00	CONNECTOR, TUBE, 3/4-18/18 X 3/16-18 THD
5	2	00-6693-0001-00	PLUG, PLASTIC SQUARE
6	2	00-0238-0002-00	WASHER, LK SAE STD MED 5/16" PL. REPLCS HW0007
7	2	00-0682-0900-12	SCREW, BTN. HD SKT PL. 5/16-18 X 1 1/2" LC

SIZE	MAIN ASSEMBLY USAGE				SUB-ASSEMBLY USED ON				
	10CO	20CO	10EP	20EP	10HP	20HP	40	ASSEMBLY	ASSEMBLY
4									
8									
14									
18									
24									
36									

DRAWN: D.L. WEST		DATE: 01/15/02
CHECKED:		DATE:
APPR:		DATE:
PART NUMBER: 28-8204-3500-50		REV: B
DRAWING TITLE: CARRIER, FACER/HEATER ASSEMBLY, 14M		SCALE: 1:1

NOTES:
 1. USE LOCTITE 262 ON SCREW 00-0685-0500-08.

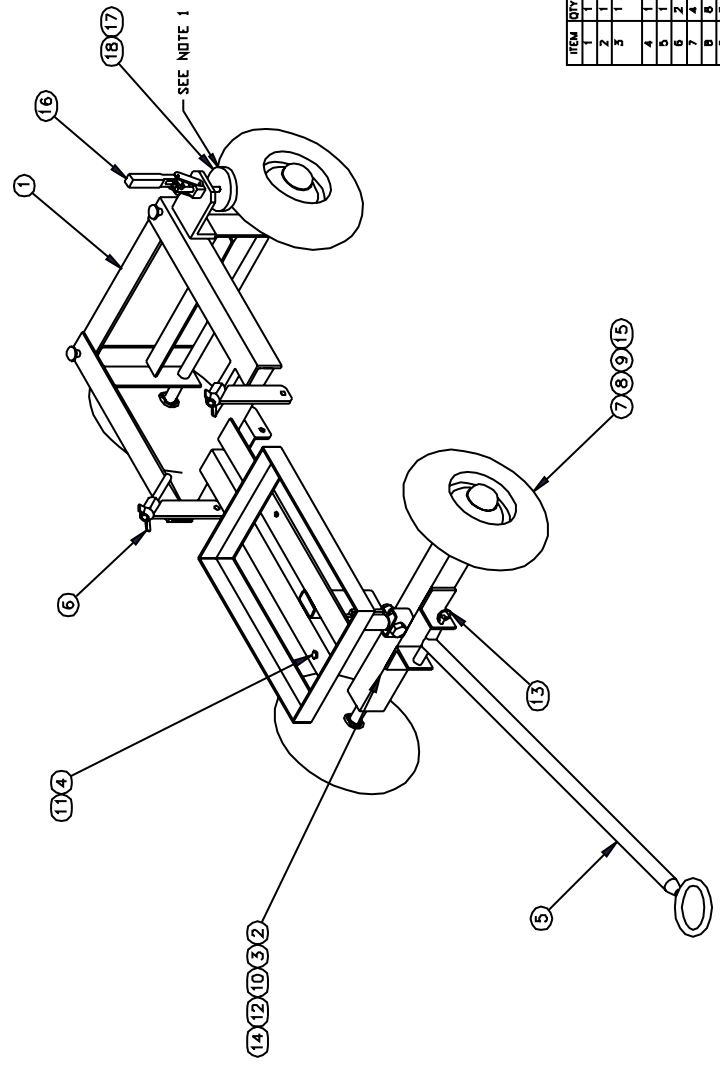

REV	DATE	DESCRIPTION
CS	A	REMOVED TO-6883-0001-00, 00-6882-0001-00, AND 00-0042-0002-00. ADDED V00016, 00-0685-0500-08, AND 100049

ITEM	QTY	PART NUMBER	DESCRIPTION
1	1	28-8204-5010-20	CART FRAME
2	1	28-8204-5020-20	FRONT AXLE
3	1	00-0203-1000-16	BOLT, HEX HD 625-11 X 2" SAE OR 5-ZINC PL-REPLICS HB0052
4	1	00-6960-0001-00	PNL, COTTER. RUL RING, RUL-14-5
5	1	28-8204-5030-20	TOW HANDLE
6	2	28-8204-5040-20	HING SCREW
7	4	27-8018-8110-10	RUB CAP
8	2	27-8022-8110-11	RETAINING RING
9	2	27-8022-2510-11	WASHER, FLAT, 3/4
10	4	00-0685-0500-08	SCREW FHSR 5/16-18 X 1 Z P REPLCS
11	4	00-1178-0014-00	NUT, ENR 5/8-11UNC-3 LL STD HGT PLTD
12	1	00-1737-0016-00	PNL, COTTER. RUL RING, RUL-14-5
13	1	00-4274-0640-00	PNL, CLUCK RELEASE, .375 DIA X 4.00 CRIP
14	2	00-5568-0008-00	BUSHING, FLANGE
15	4	00-6964-0001-00	WHEEL / TIRE ASSY, 400
16	1	V00016	CLAMP, DESTACO 804
17	1	00-0685-0500-08	SCREW FHSR 5/16-18 X 1 Z P REPLCS
18	1	100049	PNL, BRAKE

SIZE	MAIN ASSEMBLY USAGE				SUB-ASSEMBLY USED ON			
	10CQ	20CQ	10HP	20HP	QTY	ASSEMBLY	QTY	ASSEMBLY
4					40			
8								
14								
18								
24								
36								

CONNECTRA FUSION TECHNOLOGIES, LLC
 CART ASSEMBLY, 14M

DATE: 01/16/02
 APPR: D.L.WEST
 CHECKED: [Signature]

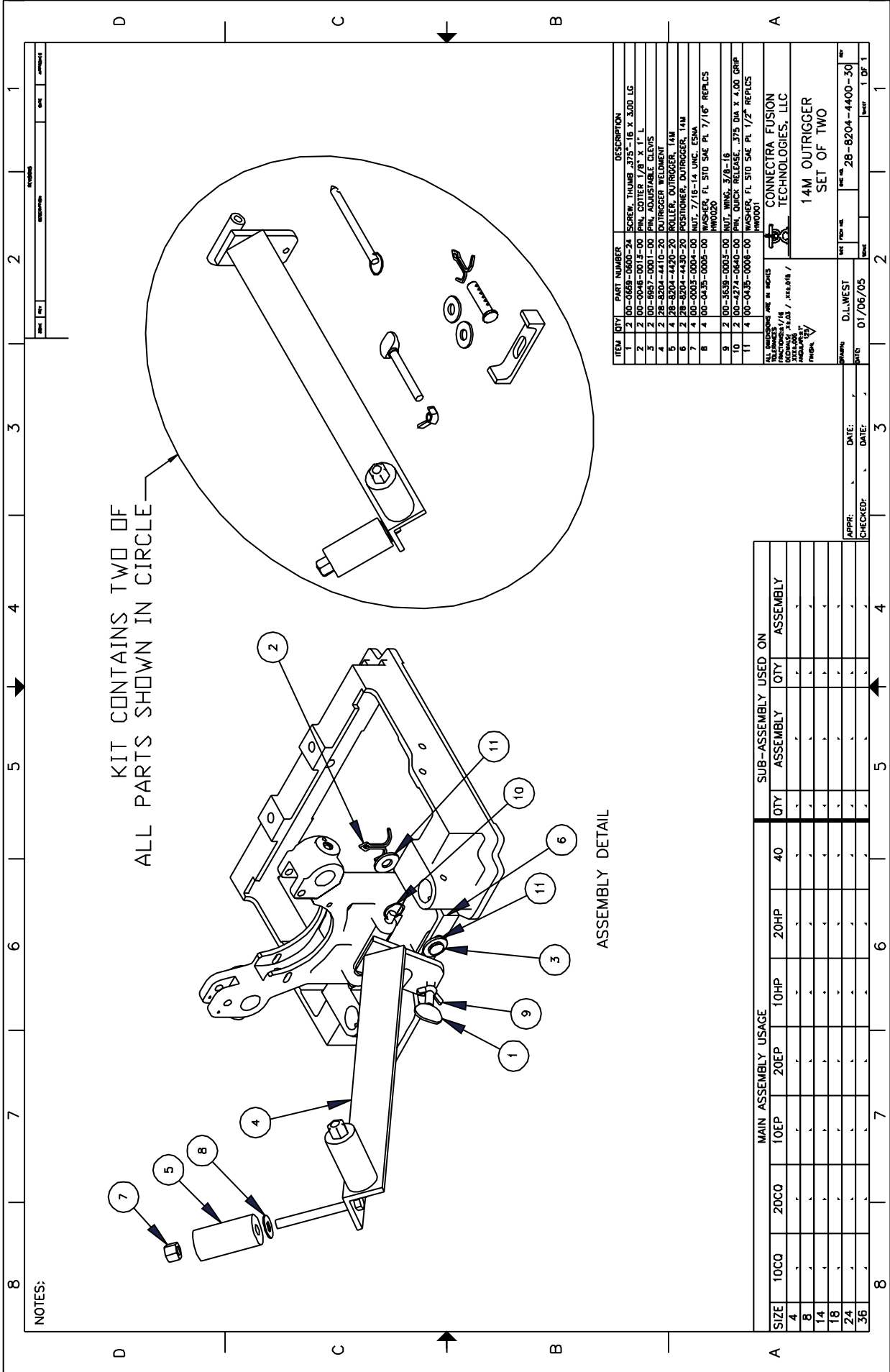

KIT CONTAINS TWO OF ALL PARTS SHOWN IN CIRCLE

ASSEMBLY DETAIL

ITEM	QTY	PART NUMBER	DESCRIPTION
1	2	00-0665-0600-24	SCREW, THUMB, .375" DIA X 3.00 LG
2	2	00-0046-0015-00	PIN, COTTER, 1/8" X 1" L
3	2	00-0967-0001-00	PIN, ADJUSTABLE CLEVIS
4	2	28-8204-4410-20	OUTRIGGER WELDMENT
5	4	28-8204-4420-20	ROLLER, OUTRIGGER, 14M
6	2	28-8204-4430-20	POSITIONER, OUTRIGGER, 14M
7	4	00-0003-0004-00	NUT, 7/16"-14 UNC, ESM
8	4	00-0435-0005-00	WASHER, FL 5/16 DIA X 1/2 REPLCS
9	2	00-1639-0006-00	WASHER, 3/8" DIA X 1/2 REPLCS
10	2	00-2372-0460-00	NUT, 3/8" DIA X 1/2 REPLCS
11	4	00-0435-0006-00	WASHER, FL 5/16 DIA X 1/2 REPLCS

ALL DIMENSIONS ARE IN INCHES UNLESS OTHERWISE SPECIFIED DIMENSIONS IN PARENTHESIS / ARE FOR / REFERENCE ONLY FINISH:		CONNECTRA FUSION TECHNOLOGIES, LLC 14M OUTRIGGER SET OF TWO
APPR:	D.L. WEST	REV: 28-8204-4400-30
CHECKED:	DATE: 01/06/05	DATE: 01/06/05
		REV: 1 OF 1

SIZE	MAIN ASSEMBLY USAGE			SUB-ASSEMBLY USED ON		
	10EP	20EP	20HP	QTY	ASSEMBLY	ASSEMBLY
4	-	-	40	-	-	-
8	-	-	-	-	-	-
14	-	-	-	-	-	-
18	-	-	-	-	-	-
24	-	-	-	-	-	-
36	-	-	-	-	-	-

NOTES: